



LONWORKS<sup>®</sup> インタフェースカード  
LONWORKS<sup>®</sup> Interface Card  
"OPC-LNW"

日本語

ENGLISH

# Preface

Thank you for purchasing our LONWORKS Interface Card "OPC-LNW."

Installing this card on your inverter makes it possible from other LONWORKS devices in the network to issue run and speed commands and monitor the inverter running status, using LONWORKS parameters. It also enables modification and monitoring of the inverter configuration as well as writing to and reading from the inverter's function codes.

This instruction manual does not contain inverter handling instructions. Read through this instruction manual in conjunction with the inverter Instruction Manual and be familiar with proper handling and operation of this product. Improper handling might result in incorrect operation, a short life, or even a failure of this product.

Keep this manual in a safe place.

## Related Publications

Listed below are the other materials related to the use of the LONWORKS interface card. Read them in conjunction with this manual as necessary.

- RS-485 Communication User's Manual
- Inverter instruction Manual

The materials are subject to change without notice. Be sure to obtain the latest editions for use.

A figure, existence of a terminal, a function code, an alarm code, etc. which have been written in this manual may change with object inverters.

## How this manual is organized

This manual is made up of chapters 1 through 10.

### **Chapter 1 Features**

Gives an overview of the main features of the LONWORKS interface card.

### **Chapter 2 Acceptance Inspection**

Lists points to be checked upon delivery of the interface card and precautions for transportation and storage of the card. Also this chapter presents the appearance of the card and provides information on how to obtain an XIF file and LNS plug-in.

### **Chapter 3 Basic Functions**

Provides instructions on how to use the service button and status indicator LEDs.

### **Chapter 4 Installation and Removal**

Provides instructions and precautions for installing the interface card.

### **Chapter 5 Wiring**

Provides wiring instructions around the Basic Connection Diagram and the terminal blocks on the interface card and the cable specifications.

### **Chapter 6 Function Code Settings Required for LONWORKS Communication**

Describes the inverter's function codes to be set for receiving run and frequency commands via LONWORKS network. It also lists the related function codes.

### **Chapter 7 Object Details**

Describes the objects supported by the interface card and their network variables (NV) and configuration properties (CP).

### **Chapter 8 Inverter Reaction to LONWORKS Communications Errors**

Describes on how the inverter operates if a LONWORKS communications error occurs.

### **Chapter 9 Troubleshooting**

Provides troubleshooting instructions for certain problems, e.g., when the inverter does not operate as ordered or when an alarm condition has been recognized.

### **Chapter 10 Specifications**

Lists the general specifications and communications specifications.

## Icons

The following icons are used throughout this manual.

 **Note** This icon indicates information which, if not heeded, can result in the product not operating to full efficiency, as well as information concerning incorrect operations and settings which can result in accidents.

 **Tip** This icon indicates information that can prove handy when performing certain settings or operations.

 This icon indicates a reference to more detailed information.

## Table of Contents

Preface .....	1	Chapter 7 Object Details .....	12
How this manual is organized .....	1	7.1 Overview .....	12
Chapter 1 Features .....	3	7.2 Node Object .....	12
Chapter 2 Acceptance Inspection .....	3	7.3 VSD Object .....	14
Chapter 3 Basic Functions .....	4	7.4 VSD Object Input Network Variables .....	22
3.1 Service Button .....	4	7.5 VSD Object Output Network Variables .....	26
3.2 Status Indicator LEDs .....	4	7.6 Reading and Writing from/to Inverter's Function Codes .....	31
3.3 Terminal Blocks .....	4	7.7 VSD Object Configuration Properties (CPs) .....	34
3.4 Barcode Label .....	4	Chapter 8 Inverter Reaction to LONWORKS Communications Errors .....	36
Chapter 4 Installation and Removal .....	5	8.1 Specifying an Inverter Reaction to LONWORKS Communications Errors .....	36
4.1 Installing the Interface Card .....	5	Chapter 9 Troubleshooting .....	37
4.2 Removing the Interface Card .....	6	Chapter 10 Specifications .....	38
Chapter 5 Wiring .....	7	10.1 General Specifications .....	38
5.1 Basic Connection Diagram .....	7	10.2 Communications Specifications .....	38
5.2 Wiring to the Terminal Blocks .....	7		
5.3 Wiring to Inverter .....	9		
Chapter 6 Function Code Settings Required for LONWORKS Communication .....	10		

# Chapter 1 Features

The LONWORKS interface card has the following features:

- Baud rate : 78 kbps
- Profile : Variable Speed Motor Drive Functional Profile Version 1.1 compliant
- Network topology : Free topology (Bus, Star, Loop and Hybrid)
- Network variables (NVs): 62 in total
- Able to read and write all function codes supported in Inverter



**IMPORTANT**

After commissioning of this card, be sure to restart the inverter or reset it with a LONWORKS integration tool (e.g., LonMaker). Until it is done, the changes made for network variables (NVs) or configuration properties (CPs) will not be validated on the inverter.

# Chapter 2 Acceptance Inspection

Unpack the package and check that:

- (1) A LONWORKS interface card is contained in the package.
- (2) The interface card has not been damaged during transportation--no defective electronic devices, dents, or warp.
- (3) The model name "OPC -LNW" is printed on the interface card. (See Figure 2-1.)
- (4) A barcode label (representing Neuron ID) is attached to the interface card. Another barcode label (not attached to the card) comes with the card.

If you suspect the product is not working properly or if you have any questions about your product, contact your Fuji Electric representative.



- Please check the user's manual of an inverter about an object inverter and a ROM version.



-None of an XIF file and resource file comes with the LONWORKS interface card.

These files can be downloaded for free (registration required) from our website at:

<https://felib.fujielectric.co.jp/download/index.htm?site=global&lang=en>

-A LONWORKS integration tool does not come with the interface card. Get the one separately. The recommended tool is Echelon LonMaker.

- The Neuron ID is printed on the barcode label. The barcode symbology is Code 39.

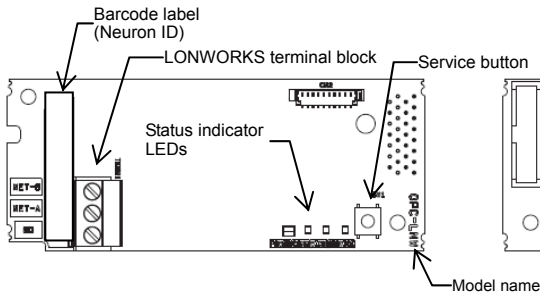

Figure 2-1 Front of the Interface Card

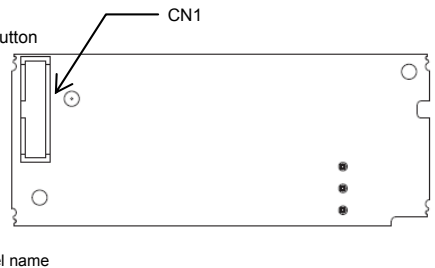

Figure 2-2 Back of the Interface Card

## Chapter 3 Basic Functions

### 3.1 Service Button

The service button is used to commission the LONWORKS interface card to the network. Pressing the button outputs the Neuron ID to the network.



Setting inverter's function code o30 to "1" is functionally equivalent to the depression of the service button. The function code enables commission from the keypad so as not to require removing the inverter cover, making it safe and convenient.

## WARNING

When pressing the service button, take extra care not to touch the inverter high-voltage section. Setting inverter's function code o30 to "1" is functionally equivalent to the depression of the service button, so using the function code is recommended for safety.

**Electric shock could occur.**

### 3.2 Status Indicator LEDs

The four status indicator LEDs show the status of the interface card as listed below.

Table 3-1 LED Status

Name	Color	Meaning	Note
POWER	Lights in green	Normal	--
	Blinks in green	Self-diagnostic test running or initialization in progress during powering on sequence	This test takes approx. 0.5 second.
	Blinks in red	LONWORKS communications error	The inverter shows $E-5$ . *1
	Lights in red	Hardware error (Card not properly installed or card faulty)	The inverter shows $E-4$ .
COMM	Lights in green	Occurrence of LONWORKS communications event *2	The change of an output NV value lights this LED even if the cable is not connected.
WINK	Blinks in green	WINK message received	Blinking 6 times.
SERVICE	Lights in green	Service button being pressed	--
	Blinks in green	Unconfigured	Including uncommissioned state
	Off	Configured	Including commissioned state.

\*1 Configuration for ignoring  $E-5$  is possible. For details, refer to Chapter 8, Section 8.1 "Specifying an Inverter Reaction to LONWORKS Communications Errors."

\*2 Upon completion of initialization of the interface card after the power is turned on, an event that outputs all output network variables supported by this card occurs in order to tell the latest inverter information to the network. Since this event occurs independent of the cable connection/disconnection, binding/unbinding, and commissioned/not commissioned, it lights the COMM LED. The delay time from the occurrence of the event to the output of the output network variables can be adjusted with the VSD object, UCPT\_SendDelayAfterDevRdy.



For details about UCPT\_SendDelayAfterDevRdy, refer to Section 7.3.3 "List of VSD object configuration properties (CPs)."

### 3.3 Terminal Blocks

The interface card has two terminal blocks: LONWORKS and ground.



For wirings, refer to Chapter 5 "Wiring."

### 3.4 Barcode Label

The Neuron ID assigned to the Neuron chip mounted on the interface card is printed on the barcode label pasted on the card in both human-readable character string and barcode. The barcode symbology is Code 39. One more barcode label comes with the card for application to a network drawing, etc.

## Chapter 4 Installation and Removal

### **WARNING**

Turn the power off and wait for at least ten minutes, before starting installation. Further, check that the LED monitor and charge lamp are unlit, and check the DC link circuit voltage between the P (+) and N (-) terminals to be lower than 25 VDC.

**Otherwise, electric shock could occur.**

### **CAUTION**

- Do not use the product that is damaged or lacking parts.  
**Doing so could cause a fire, an accident, or injuries.**
- Prevent lint, paper fibers, sawdust, dust, metallic chips, or other foreign materials from getting into the inverter and the interface card.  
**Otherwise, a fire or an accident might result.**
- Incorrect handling in installation/removal jobs could cause a failure.  
**A failure might result.**

#### 4.1 Installing the Interface Card

 **Note** Before mounting the interface card, perform the wiring for the main circuit terminals and control circuit terminals.

- (1) Remove the front cover from the inverter and expose the control printed circuit board (control PCB). The interface card can be connected to the option connection ports on the inverter's control PCB.

 **Note** Check the user's manual of an inverter about the connection port of the interface card.

 To remove the front cover, refer to "wiring" in the Inverter Instruction Manual.

- (2) Insert connector CN1 on the back of the interface card (Figure 2-2) into the option connection ports on the inverter's control PCB. Then tighten the two screws that come with the card. (Figure 4-2)

 **Note** Check that the positioning cutout (shown in Figure 4-1) is fitted on the tab (① in Figure 4-1) and connector CN1 is fully inserted (② in Figure 4-1). Figure 4-2 shows the interface card correctly mounted.

- (3) Perform wiring on the interface card.

 For wiring instructions, see Chapter 5.

- (4) Put the front cover back into place.

 To put back the front cover, refer to "wiring" in the Inverter Instruction Manual.

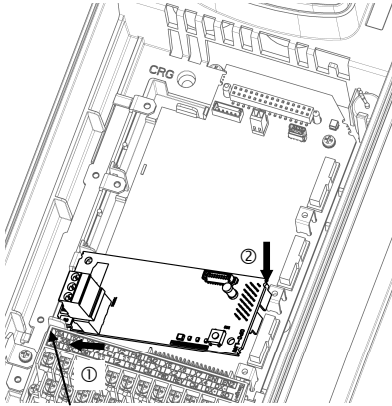

Tab

Figure 4-1 Mounting the Interface Card (to FRENIC-HVAC A-port)

- ① Fit the positioning cutout of the interface card over the tab on the inverter to determine the mounting position.
- ② Insert connector CN1 on the interface card into the option connection ports on the inverter's control PCB.

**Note:** Be sure to follow the order of ① and ②. Inserting CN1 first may lead to insufficient insertion, resulting in a contact failure.

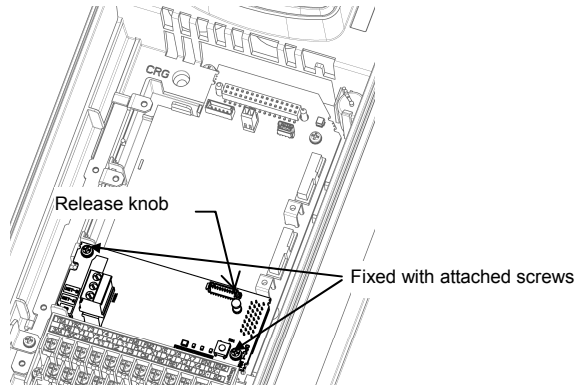

Figure 4-2 Mounting Completed (on FRENIC-HVAC A-port)

## 4.2 Removing the Interface Card

Remove the two screws that secure the interface card and pull the release knob (shown Figure 4-2) to take the interface card out of the inverter.

# Chapter 5 Wiring

## 5.1 Basic Connection Diagram

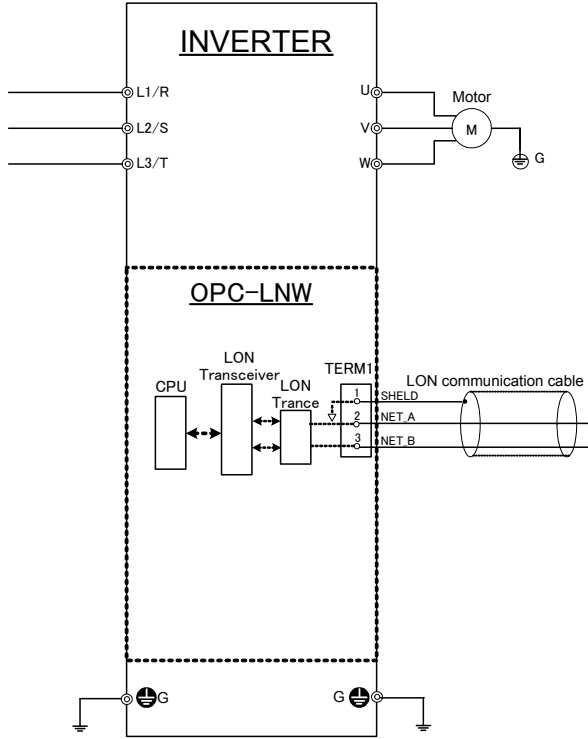

\*Mounting the interface card connects to the grounding ⓂG.

Figure 5-1 Basic Connection Diagram

## 5.2 Wiring to the Terminal Blocks

- (1) Use a shielded twist pair cable recommended by LONMARK for network connection.

**Tip** The recommended cable is LW161S manufactured by Showa Electric Wire & Cable Co., Ltd.

**Book** For details about wiring, refer to the "FT3120/FT3150 Smart Transceiver Data Book" published by Echelon. It can be downloaded for free from our website at:

<http://www.echelon.com/support/documentation/manuals/.../005-0139-01d.pdf>



(2) Wiring to the LONWORKS' terminal block (TERM1)

The terminal block uses a pluggable 3-pin connector shown in Figure 5-2. Table 5-1 shows the pin assignment.

The applicable pluggable connector is "MVSTBR2.5/3-ST-5.08" manufactured by Phoenix Contact Corporation.

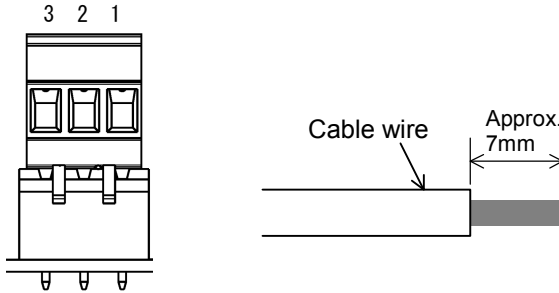

Figure 5-2 Terminal Block and Recommended Strip Length

Table 5-1 Pin Assignment on TERM1

Pin #	Pin Assignment	Description
1	SD	For shielded wire
2	NET A	For communication data
3	NET B	For communication data

The table below lists the terminal screw size and its recommended tightening torque.

Terminal screw size	M3
Tightening torque	0.5 to 0.6 [N·m]

**Tip** The network wiring is polarity insensitive. Connecting the two wires of the network cable to NET A and NET B enables communication, without regard to polarity. Wire crossing between the interface card and other nodes causes no problem.

(3) Network termination

Free topology wiring requires a single terminating resistor per segment.

**Note** No terminating resistor comes with the interface card. Prepare resistors separately. The recommended terminating resistor is "TP/FT-10 Channel Terminator Model No.44100" manufactured by Echelon.

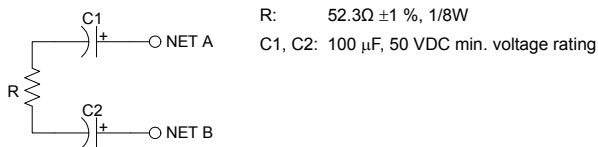

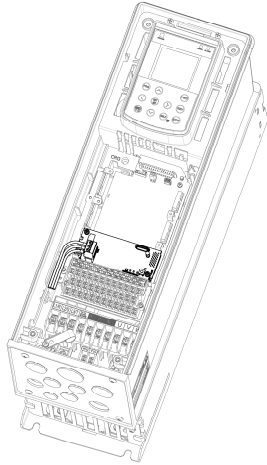

Figure 5-3 LONWORKS Network Termination

### 5.3 Wiring to Inverter

-  Note Route the wiring of the LONWORKS communications cable as far from the wiring of the main circuit as possible. Otherwise electric noise may cause malfunctions.
-  Note Route the wires, taking care not to let them go over the control PCB, malfunctions may occur.



\* Pass the wires from the interface card between the control circuit terminal block and the front cover.  
In the case of FRENIC-HVAC 7.5 kW

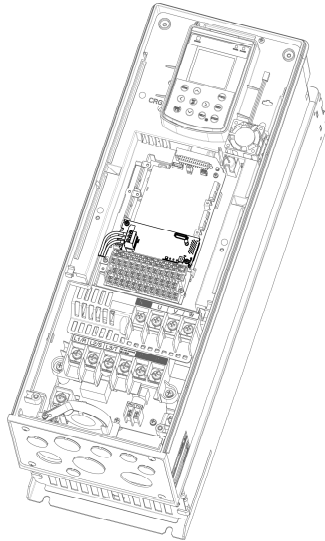

In the case of FRENIC-HVAC 22 kW

Figure 5-4 Wiring Examples

## Chapter 6 Function Code Settings Required for LONWORKS Communication

To enable run, frequency, and nviXcmd\_1 to 5 commands via the LONWORKS network, the inverter requires setting function codes listed in Table 6-1.

To enable particular NVs, modify the function codes listed in Table 6-2. To enable other functions, modify them listed in Table 6-3.

 For details about function codes, refer to the user's manual of an inverter and RS-485 Communication User's Manual (MEH448), Chapter 5, Section 5.2 "Data Formats."

 **Tip** Function code settings in Tables 6-1 through 6-3 are not essential for LONWORKS communication. Those settings can be made either before or after commissioning of the interface card.



 **Note** IMPORTANT After commissioning of the interface card, be sure to restart the inverter or reset it with a LONWORKS integration tool (e.g., LonMaker). (The card does not operate normally just by turning it online.) Until it is done, the changes made for network variables (NVs) or configuration properties (CPs) will not be validated on the inverter.

Table 6-1 Function Code Settings for Enabling Run, Frequency and nviXcmd1 to 5 Commands via LONWORKS Network

Function code	Description	Factory default	Setting Required	Remarks
y98	Run and frequency commands via LONWORKS network	0	3	Setting UCPT_LinkFunc is equivalent to setting y98.
y99	Run and frequency commands via Loader	0	0	No change is required from the factory default.
E01 to E09	Command assignment to terminals [X1] to [X9]	Depends on the target inverter	Except the following. 24, 1024 ( <b>LE</b> selected) 35, 1035 ( <b>LOC</b> selected)	- Even if <b>LE</b> is selected, turning the physical terminal ON causes no problem.  - Even if <b>LOC</b> is selected, the physical terminal OFF causes no problem.
E98	Command assignment to terminal [FWD]	98	98	No change is required from the factory default.

 **Note** The number of function codes and inverter's general-purpose input terminals differs depending on the target inverter.

To enable particular NVs listed below, modify the following function codes in addition to the ones listed in Table 6-1.

Table 6-2 Function Codes Required for Enabling nviAOcmd and nviDOcmd\_Y1 and Y2

NV to be Enabled	Function code	Description	Factory default	Setting Required
nviAOcmd	F31, F35	Analog output to terminals [FM1] and [FM2] or [FMA] and [FMP]	0, 0	10 (Universal AO)
nviDOcmd_Y1, Y2	E20, E21	Signal assignment to terminals [Y1] and [Y2]	0, 1	27 (Universal DO)

 For details about network variables (NVs), refer to Table 7-4 "VSD Object Network Variables."

To enable other functions, modify function codes listed in Table 6-3.

Table 6-3 Function Codes Required for Enabling Other Functions

Function code	Description	Factory default	Setting range	Remarks
o27* <sup>1</sup>	Operation selection at occurrence of LONWORKS communications error	0	0 to 15	Can be specified by UCPT_CblLossMode.
o28* <sup>1</sup>	Timer at occurrence of LONWORKS communications error	0.0 s	0.0s to 60.0 s	Can be specified by UCPT_CblLossTimer.
o30	Service button equivalent	0	0 to 255	Setting o30 to "1" or above is functionally equivalent to the depression of the service button. Once o30 data is changed, it will automatically revert to "0."
W90	LONWORKS card software version	Depends on cards	-- (Only for monitor)	4-digit in decimal notation. (Ex.) Ver. 1.42 is shown as 0142.
W95	Count of communications errors between card and inverter	0	-- (Only for monitor)	
W96	Contents of communications errors between card and inverter (Transmission errors only * <sup>2</sup> )	0	-- (Only for monitor)	Contents of the most recent communications error. The error codes are identical with the ones used in the Fuji general-purpose inverter protocol. * <sup>3</sup>

\*<sup>1</sup> For details about o27 and o28, refer to Chapter 8, Section 8.1 "Specifying an Inverter Reaction to LONWORKS Communications Errors."

\*<sup>2</sup> Application errors except transmission errors will be written into the VSD object, nv34 nvoAccessErrCode. For details about error code contents, refer to Chapter 7, Section 7.6.2 "Writing to inverter's function codes."

\*<sup>3</sup> For error code details, refer to the RS-485 Communication User's Manual (MEH448), Chapter 4, Section 4.3 "Communications Errors."

# Chapter 7 Object Details

## 7.1 Overview

The interface card supports two objects--a node object and Variable Speed Motor Drive object (VSD object). This chapter provides detailed information on these objects.

## 7.2 Node Object

### 7.2.1 Node object overview

The node object processes the system events in LONWORKS network communication for the interface card. (Usually any intervention of users or integrators is not required.)

Figure 7-1 illustrates the relationship between a node object and network variables (NVs).

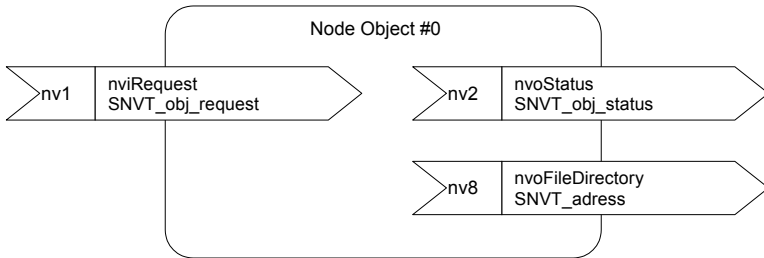

Figure 7-1 Overview Structure of Node Object

### 7.2.2 List of node object network variables (NVs)

Table 7-1 lists node object network variables supported on the interface card.

Table 7-1 Node Object Network Variables

Index	Variable name	Variable type	Description
nv1	nviRequest	SNVT_obj_request	This variable is used to request a particular mode for an object. Requests supported: - RQ_NORMAL(0) - RQ_ENABLED(7) - RQ_DISABLED(1) - RQ_UPDATE_STATUS(2) - RQ_REPORT_MASK(5) - RQ_CLEAR_ALARM(10)
nv2	nvoStatus	SNVT_obj_status	This variable is used to report the status of an object. Statuses supported: - object_id - invalid_id - invalid_request - disabled - in_alarm - report_mask
nv8	nvoFileDirectory	SNVT_adress	This variable is used to provide the starting address of the directory that contains the configuration file.

**7.2.3 NV details**

(1) nviRequest

Table 7-2 lists responses to the request modes of nviRequest.

Table 7-2 Responses to nviRequest

Request	Node object response	VSD object response
RQ_NORMAL(0)	<ul style="list-style-type: none"> <li>- Enables the node object and NVs to the normal mode.</li> <li>- Updates nvoStatus and outputs the new object status.</li> </ul>	<ul style="list-style-type: none"> <li>- Enables the VSD object and NVs to the normal mode.</li> <li>- Updates nvoStatus and outputs the new object status.</li> </ul>
RQ_ENABLE(7)	Same as above.	Same as above.
RQ_DISABLE(1)	<ul style="list-style-type: none"> <li>- Stops the motor if running.</li> <li>- Keeps the node object enabled.</li> <li>- Updates nvoStatus and outputs the new object status.</li> </ul>	<ul style="list-style-type: none"> <li>- Stops the motor if running.</li> <li>- Disables the VSD object, ignores NV input, and forbids its output to transmit.</li> <li>- Updates nvoStatus and outputs the new object status.</li> </ul>
RQ_UPDATE_STATUS(2)	<ul style="list-style-type: none"> <li>- Updates nvoStatus and outputs the new object status.</li> </ul>	<ul style="list-style-type: none"> <li>- Updates nvoStatus and outputs the new object status.</li> </ul>
RQ_REPORT_MASK(5)	<ul style="list-style-type: none"> <li>- Reports supported requests as "1."</li> <li>- Updates nvoStatus and outputs the new object status.</li> </ul>	<ul style="list-style-type: none"> <li>- Reports supported requests as "1."</li> </ul>
RQ_CLEAR_ALARM(10)	<ul style="list-style-type: none"> <li>- Resets alarm.</li> <li>- Updates nvoStatus and outputs the new object status.</li> </ul>	<ul style="list-style-type: none"> <li>- Resets alarm.</li> <li>- Updates nvoStatus and outputs the new object status.</li> </ul>
All other requests	<ul style="list-style-type: none"> <li>- Returns an invalid request response.</li> <li>- Updates nvoStatus and outputs the new object status.</li> </ul>	<ul style="list-style-type: none"> <li>- Returns an invalid request response.</li> <li>- Updates nvoStatus and outputs the new object status.</li> </ul>
All other objectIDs	<ul style="list-style-type: none"> <li>- Returns an invalid request response.</li> <li>- Updates nvoStatus and outputs the new object status.</li> </ul>	<ul style="list-style-type: none"> <li>- Returns an invalid request response.</li> <li>- Updates nvoStatus and outputs the new object status.</li> </ul>

(2) nvoStatus

Table 7-3 lists the status network variables supported and their descriptions.

Table 7-3 Status Network Variables Supported

Status	Description
object_id	Returns the object ID designated by the Request.
invalid_id	Turns "1" when Request is issued to an object with invalid ID.
invalid_request	Turns "1" for an invalid request response.
disabled	Turns "1" when the VSD object is disabled.
in_alarm	Turns "1" when the inverter is in an alarm state or has not solved an alarm.
report_mask	Turns the value of the supported status to "1."

**7.2.4 Configuration properties (CPs)**

Configuration properties are not supported for the node object.

## 7.3 VSD Object

### 7.3.1 VSD object overview

The Variable Speed Motor Drive (VSD) object allows you to control the inverter and monitor its running status. Figure 7-2 illustrates an overview structure of a VSD object. Letters in parenthesis at the tail of the NV name strings show the names of the inverter's function codes that are involved by the related NVs.

 For details about the function codes in parenthesis, refer to the RS-485 Communication User's Manual (MEH448), Chapter 5, "FUNCTION CODES AND DATA FORMATS."

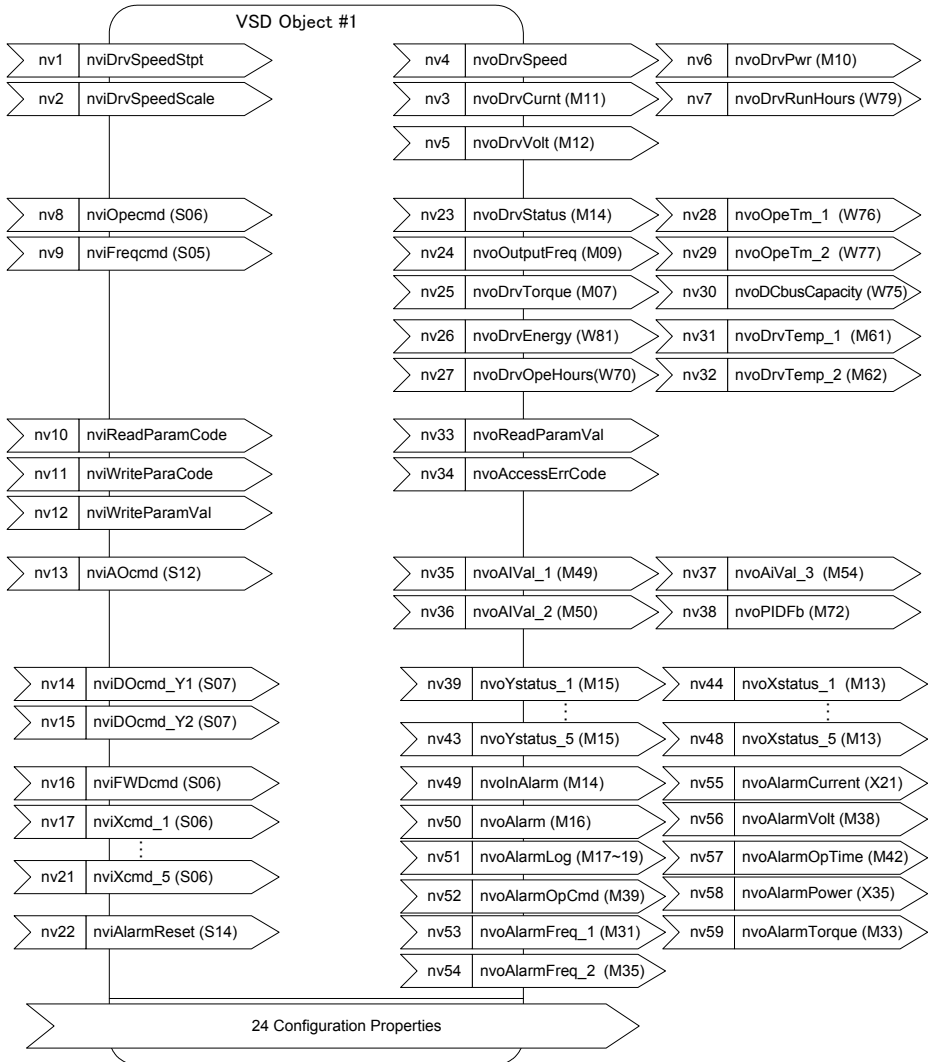

Figure 7-2 Overview Structure of VSD Object

### 7.3.2 List of VSD object network variables (NVs)

Table 7-4 lists the summary of VSD object network variables (NVs). The function code column in the table shows their associated inverter's function codes.

Some of the VSD object input and output NVs are detailed in Sections 7.4 and 7.5, respectively.

Table 7-4 VSD Object Network Variables

Index	Variable name	Variable type	Descriptions	Function code	Refer to:
nv1	nviDrvSpeedStpt	SNVT_switch	This input provides start/stop commands and a low-resolution speed setpoint. (as a percentage of SCPT_nomFreq)	-	p. 22
nv2	nviDrvSpeedScale	SNVT_lev_percent	This input provides scaling for a low-resolution speed setpoint. (Negative values indicate reverse motor direction.)	-	p. 22
nv3	nvoDrvCurnt	SNVT_amp	This output reports the output current (RMS) with 0.1 A resolution.	M11	-
nv4	nvoDrvSpeed	SNVT_lev_percent	This output reports the output speed. (as a percentage of SCPT_nomFreq)	-	p. 26
nv5	nvoDrvVolt	SNVT_volt	This output reports the output voltage (RMS) with 0.1 V resolution.	M12	-
nv6	nvoDrvPwr	SNVT_power_kilo	This output reports the output power with 0.1 kW resolution.	M10	-
nv7	nvoDrvRunHours	SNVT_time_hour	This output reports the cumulative motor run time. (Diagnostic reference of the mechanical component service life)	Z40	-
nv8	nviOpeCmd	SNVT_state	This input provides run commands including run forward command, run reverse command, and terminal commands assigned to general-purpose, digital input terminals. Functionally equivalent to function code S06 (dedicated to inverter communication).	S06	p. 23
nv9	nviFreqCmd	SNVT_freq_hz	This input provides frequency command with 0.1 Hz resolution.	S05	p. 23
nv10	nviReadParamCode	SNVT_count	This input specifies a target inverter's function code to read out its data to nv33 nvoReadParamVal.	-	pp. 23 and 31
nv11	nviWriteParaCode	SNVT_count	This input specifies a target inverter's function code to write data with nv12 nviWriteParamVal.	-	pp. 24 and 32
nv12	nviWriteParamVal	SNVT_count	This input contains data to write into the inverter's function code specified by nv11 nviWriteParaCode. The write result is output to nv34.	-	pp. 24 and 32
nv13	nviAOcmd	SNVT_lev_percent	This input specifies any output level for the inverter's analog output terminal. Functionally equivalent to function code S12 (dedicated to inverter communication).	S12	pp. 24 and 10
nv14	nviDOcmd_Y1	SNVT_switch	This input turns the inverter's digital output terminal [Y1] ON/OFF. If the value is "1," [Y1] is ON. (Setting E20 to "27" (Universal DO) is needed.)	S07	pp. 24 and 10
nv15	nviDOcmd_Y2	SNVT_switch	This input turns the inverter's digital output terminal [Y2] ON/OFF. If the value is "1," [Y2] is ON. (Setting E21 to "27" (Universal DO) is needed.)	S07	pp. 24 and 10
nv16	nviFWDcmd	SNVT_switch	This input turns terminal command <b>FWD</b> (bit XF of S06) ON/OFF, which is assigned to the inverter's digital input terminal [FWD] with function code E98. <b>FWD</b> runs a motor forward by factory default.	S06	pp. 25 and 10



Index	Variable name	Variable type	Descriptions	Function code	Refer to:
nv17	nviXcmd_1	SNVT_switch	This input turns a terminal command (bit X1 of S06) ON/OFF, which is assigned to the inverter's digital input terminal [X1] with function code E01.	S06	pp. 25 and 10
nv18	nviXcmd_2	SNVT_switch	This input turns a terminal command (bit X2 of S06) ON/OFF, which is assigned to the inverter's digital input terminal [X2] with function code E02.	S06	pp. 25 and 10
nv19	nviXcmd_3	SNVT_switch	This input turns a terminal command (bit X3 of S06) ON/OFF, which is assigned to the inverter's digital input terminal [X3] with function code E03.	S06	pp. 25 and 10
nv20	nviXcmd_4	SNVT_switch	This input turns a terminal command (bit X4 of S06) ON/OFF, which is assigned to the inverter's digital input terminal [X4] with function code E04.	S06	pp. 25 and 10
nv21	nviXcmd_5	SNVT_switch	This input turns a terminal command (bit X5 of S06) ON/OFF, which is assigned to the inverter's digital input terminal [X5] with function code E05.	S06	pp. 25 and 10
nv22	nviAlarmReset	SNVT_switch	Turning this variable ON (TRUE) clears alarm in the inverter. Once it turns ON, it automatically returns to OFF (False).	S14	p. 25
nv23	nvoDrvStatus	SNVT_state	This output reports the running status. Functionally equivalent to function code M14 (dedicated to inverter communication).	M14	p. 26
nv24	nvoOutputFreq	SNVT_freq_hz	This output reports the output frequency with 0.1 Hz resolution.	M09	-
nv25	nvoDrvTorque	SNVT_lev_percent	This output reports the output torque as a percentage of the rated torque with 0.005% resolution.	M07	-
nv26	nvoDrvEnergy	SNVT_elec_kwh	This output reports the inverter's cumulative power consumption in watt-hours.	W81	-
nv27	nvoDrvOpeHours	SNVT_time_hour	This output reports the cumulative inverter run time. (Diagnostic reference data for inverter lifetime)	W70	-
nv28	nvoOpeTm_1	SNVT_time_hour	This output reports the cumulative run time of electrolytic capacitors on printed circuit boards. (Diagnostic reference data for service lifetime of the control circuit)	W67	-
nv29	nvoOpeTm_2	SNVT_time_hour	This output reports the cumulative run time of the cooling fan.	W68	-
nv30	nvoDCbusCapacity	SNVT_lev_percent	This output reports the current capacitance of the DC link bus capacitor in %, based on the capacitance when shipped as 100%.	W75	-
nv31	nvoDrvTemp_1	SNVT_temp	This output reports the inverter internal temperature with 1°C resolution.	M61	-
nv32	nvoDrvTemp_2	SNVT_temp	This output reports the heat sink temperature with 1°C resolution.	M62	-
nv33	nvoReadParamVal	SNVT_count	This outputs function code data read. For the format, refer to Section 7.6.	-	pp. 26 and 31
nv34	nvoAccessErrCode	UNVT_ErrCode (1byteHex x 3)	This outputs the error code and accessed function code after completion of writing to inverter's function code. It updates only when accessed to nv11 and nv12 and outputs to LON.	-	pp. 27 and 32

Index	Variable name	Variable type	Descriptions	Function code	Refer to:
nv35	nvoAlval_1	SNVT_lev_percent	This output reports the input voltage at terminal [I2]. (100% at 10 V, 0% at 0 V)	M49	p. 27
nv36	nvoAlval_2	SNVT_lev_percent	This output reports the input current at terminal [C1]. (100% at 20 mA, 0% at 4 mA or 0 mA)	M50	p. 27
nv37	nvoAlval_3	SNVT_lev_percent	This output reports the input voltage at terminal [V2]. (100% at 10 V, 0% at 0 V)	M54	p. 27
nv38	nvoPIDFb	SNVT_lev_percent	This output reports the PID feedback value (%).	M72	p. 28
nv39	nvoYstatus_1	SNVT_switch	This output reports the status of digital output terminal [Y1] whose function is assigned by E20.	M15	p. 28
nv40	nvoYstatus_2	SNVT_switch	This output reports the status of digital output terminal [Y2] whose function is assigned by E21.	M15	p. 28
nv41	nvoYstatus_3	SNVT_switch	This output reports the status of digital output terminal [Y3] whose function is assigned by E22.	M15	p. 28
nv42	nvoYstatus_4	SNVT_switch	Reserved.	-	-
nv43	nvoYstatus_5	SNVT_switch	This output reports the status of digital output terminal [Y5A/C] whose function is specified by E24.	M15	p. 28
nv44	nvoXstatus_1	SNVT_switch	This output reports the status of a terminal command assigned to digital input terminal [X1]. When E01 data is "25" (Universal DI), this output reports the ON/OFF state of the physical terminal [X1].	M13	p. 28
nv45	nvoXstatus_2	SNVT_switch	This output reports the status of a terminal command assigned to digital input terminal [X2]. When E02 data is "25" (Universal DI), this output reports the ON/OFF state of the physical terminal [X2].	M13	p. 28
nv46	nvoXstatus_3	SNVT_switch	This output reports the status of a terminal command assigned to digital input terminal [X3]. When E03 data is "25" (Universal DI), this output reports the ON/OFF state of the physical terminal [X3].	M13	p. 28
nv47	nvoXstatus_4	SNVT_switch	This output reports the status of a terminal command assigned to digital input terminal [X4]. When E04 data is "25" (Universal DI), this output reports the ON/OFF state of the physical terminal [X4].	M13	p. 28
nv48	nvoXstatus_5	SNVT_switch	This output reports the status of a terminal command assigned to digital input terminal [X5]. When E05 data is "25" (Universal DI), this output reports the ON/OFF state of the physical terminal [X5].	M13	p. 28
nv49	nvoInAlarm	SNVT_switch	This output remains ON when the inverter is in an alarm state or has not canceled the recent alarm.	M14	-
nv50	nvoAlarm	UNVT_alarm_cod (1 byte decimal)	This output reports the code of an alarm that is occurring or has occurred most recently.	M16	p. 29

Index	Variable name	Variable type	Descriptions	Function code	Refer to:
nv51	nvoAlarmLog	UNVT_alarm_log (1 byte dec x 3)	This output reports three recent alarm codes in the order of 1st, 2nd, and 3rd recent ones.	M17 M18 M19	p. 30
nv52	nvoAlarmOpCmd	SNVT_state	The status of run command (S06) at the time of alarm.	M39	-
nv53	nvoAlarmFreq_1	SNVT_freq_hz	This output reports the status of a frequency command being executed when the most recent alarm occurred, with 0.1 Hz resolution.	M31	-
nv54	nvoAlarmFreq_2	SNVT_freq_hz	This output reports the output frequency being applied when the most recent alarm occurred, with 0.1 Hz resolution.	M35	-
nv55	nvoAlarmCurrent	SNVT_amp	This output reports the output current being applied when the most recent alarm occurred, with 0.1 A resolution.	X21	-
nv56	nvoAlarmVolt	SNVT_volt	This output reports the output voltage being applied when the most recent alarm occurred, with 0.1 V resolution.	M38	-
nv57	nvoAlarmOpTime	SNVT_time_hour	This output reports the inverter's run time being accumulated until the most recent alarm occurred.	M42	-
nv58	nvoAlarmPower	SNVT_power_kilo	This output reports the inverter's power consumption detected when the most recent alarm occurred, with 0.1 kW resolution.	X35	-
nv59	nvoAlarmTorque	SNVT_lev_percent	This output reports the inverter's output torque detected when the most recent alarm occurred, as a percentage of the rated torque with 0.005% resolution.	M33	-



Fan-out connection using aliases (branching a single output NV to two or more input NVs on this interface card) should be avoided because the interface card may miss-fetch any input NV depending upon the fetch timing. If it cannot be avoided, use the repeated mode for the connection messaging service to prevent miss-fetch of the branched NV aliases.

### 7.3.3 List of VSD object configuration properties (CPs)

Table 7-5 lists the summary of VSD object configuration properties (CPs). The function code column in the table shows their associated inverter's function codes. Modifying function code data can change the associated CP value.

Some of these CPs have detailed descriptions in Section 7.7 (see the page given in the table below).

 Refer to the user's manual of an inverter, "FUNCTION CODES" for supplementary information on the CPs.

Table 7-5 VSD Object CPs

CP name	Unit	Description	Default	Function code	Refer to:
SCPT_maxSetpoint	0.005%	Defines the maximum frequency as a percentage of SCPT_nomFreq.	100.000 % (60 Hz)	F03	-
SCPT_minSetpoint	0.005%	Defines the lower limit of the output frequency as a percentage of SCPT_nomFreq.	0.000%	F16	-
SCPT_maxSendTime	0.1 s	Sets the heartbeat send interval. The concerned NV continues transmitting data at this time intervals, regardless the data changing. Specifying 0.0 s disables this CP.	0.0 s	-	p. 33
SCPT_nomRPM	1 r/min	Used to enter the nominal speed, 100% of the percent speed command, in r/min. Modifying this CP automatically replaces the value of SCPT_nomFreq.	1800 r/min	-	-
SCPT_nomFreq	0.1 Hz	Used to enter the nominal frequency, 100% of the percent speed command, in Hz. All percent speed commands refer to this value.	60.0 Hz	-	p. 22
SCPT_rampUpTm	0.1 s	Used to enter the ramp-up time from the zero to maximum speed.	20.0 s	F07	-
SCPT_rampDownTm	0.1 s	Used to enter the ramp-down time from the maximum to zero speed.	20.0 s	F08	-
(UCPT_rampUpTm2)	-	Reserved.	-	-	-
(UCPT_rampDownTm2)	-	Reserved.	-	-	-
SCPT_defScale	0.005%	Contains the default value for nviDrvSpeedScale.	100.000 %	-	-
SCPT_maxRcvTime	0.1 s	Sets the heartbeat receive interval. If the concerned NV receives no data within this interval, it interprets the transmission as being broken. Specifying 0.0 s disables this CP.	0.0 s		p. 33
SCPT_minDeltaLevel	0.5%	Sets the minimum data change rate for an output NV to start data transmission. If the data change rate exceeds this value, the concerned NV interprets the data as being changed, starting data transmission. Specifying 0.0% disables this CP.	0.0%		p. 34
SCPT_minSendTime	0.1 s	Sets the minimum pause time for an output NV to start data transmission. Once the concerned NV finishes data transmission, it does not start data transmission until this time has elapsed even if the data change rate exceeds SCPT_minDeltaLevel. Setting 0.0 s disables this CP.	0.5 s		p. 34
UCPT_BaseFreq	0.1 Hz	Sets the base frequency of the inverter for motor 1.	50.0 Hz	F04	-
(UCPT_JogFreq)	-	Reserved.	-	-	-

CP name	Unit	Description	Default	Function code	Refer to:
UCPT_JumpFreq	0.1 Hz x 4	Contains an ensemble of four inverter's function codes specified in the array order shown below. "Jump frequency 1, 2, 3 and jump frequency band"	0.0 Hz, 0.0 Hz, 0.0 Hz, 3.0 Hz	C01, C02, C03, C04	-
UCPT_LinkFunc	1	Switches run and speed commands between "enable" and "disable" via the LONWORKS network.  Functionally equivalent to function code y98. Setting y98 data to "3" enables run and speed commands.	0	y98	p. 10
UCPT_multStepFreq1	0.01 Hz	Sets the frequency to be applied when multistep frequency 1 is selected.  Multistep frequency: Assigning terminal commands to digital input terminals [X1] to [X5] and [FWD] with E01 to E05 and E98 and turning those terminals ON/OFF can select the multistep frequency.	0.00 Hz	C05	-
UCPT_PIDsettings	0.001, 0.1 s, 0.01 s, 0.1 s	Contains an ensemble of four PID parameters specified in the array order shown below. "P gain, I time, D time and feedback filter time constant"	0.100, 0.0 s, 0.00 s, 0.5 s	J03, J04, J05, J06 *1	-
UCPT_StartFreq	0.1 Hz	Sets the starting frequency.	0.5 Hz	F23	-
UCPT_StopFreq	0.1 Hz	Sets the stop frequency.	0.2 Hz	F25	-
(UCPT_TorqLimit)	-	Reserved.	-	-	-
UCPT_CblLossMode	1	Specifies an action to follow when a communications line break error occurs on the LONWORKS network.  Functionally equivalent to function code o27.	0	o27	p. 35
UCPT_CblLossTimer	0.1 s	Sets the timer to determine the issuing timing of $E-5$ alarm triggered by a communications line break on the LONWORKS network.  Functionally equivalent to function code o28.	0.0 s	o28	p. 35
UCPT_FlyingStart Mode	1	Specifies the auto search for idling motor's speed. In the auto search mode, the frequency can be specified by function code H17.	0 (Disable)	H09	-
UCPT_momentary Pwr LossMode	1	Specifies the restart mode after a momentary power failure.  Functionally equivalent to function code F14.	1	F14	-
UCPT_AutoRestart	1	Specifies the number of auto-resetting times for automatically escaping the tripped state.  Functionally equivalent to function code H04. H05 specifies the reset interval.	0	H04	-
UCPT_SendDelay AfterDevRdy	0.1 s	Specifies the data transmission start delay time for the LONWORKS interface card.  The output NV starts data transmission after this delay time has elapsed from when the interface card is powered up or receives a reset command from the LONWORKS integration tool.  This CP should be used to strictly manage the starting time of data transmission on the whole network.  Specifying 0.0 s makes the NV start data transmission upon completion of initialization of the card. *2	0.0 s	—	-

\*1 These function codes differ depending on the target inverter. For details about the PID control of the inverter, refer to the "J codes" and "PID Control Block" given in the Inverter User's Manual.

- \*2 This LONWORKS interface card needs approx. 0.5 second for initialization. Therefore, specifying less than 0.5 second cannot start data transmission from the output NV until approx. 0.5 second elapses.

When the interface card is powered up, it transmits all output NVs to validate the latest inverter settings on the LONWORKS network.

**Note** Immediately after commissioning, the LONWORKS integration tool temporarily monitors CP default values, so those CP values do not necessarily match the inverter's function code settings. This is, however, only apparent and the inverter runs with its function code settings.

To make the monitored CP values match the inverter's settings, use the LONWORKS integration tool to execute the "Synchronize CP" command (e.g., ReSync CPs in LonMaker) and upload the CP values of this card.

**Note** Modifying CP-associated function codes from the keypad does not automatically update the CP values being monitored by the LONWORKS integration tool. This is, however, only apparent and the modification is validated on the associated CPs without any problems.

To update the monitored CP values, use the LONWORKS integration tool to execute the "Synchronize CP" command (e.g., ReSync CPs in LonMaker) and upload the CP values of this card.

**Tip** The moment the LONWORKS integration tool sets CP values (new or unchanged values), all output NVs implemented on this card output the latest data at that time. Use this feature to update the NVs on the network with the latest data.

In addition, switching the inverter from offline to online also outputs all output NVs as well.

## 7.4 VSD Object Input Network Variables

### (1) nv1 nviDrvSpeedStpt

This NV controls the inverter's run/stop and frequency commands via the LONWORKS network.

- Variable type: SNVT\_switch

Table 7-6 Operation of nviDrvSpeedStpt

state	value	Operation
0	NA	Run command OFF
1	0.0 (%)	Zero speed command (No torque generated)
1	0.5 to 100.0 (%)	Run at 0.5 to 100.0% frequency
-1 (0xFF)	NA	Invalid

- Default setting: state = -1, value = 0

The interface card calculates the frequency command value with nviDrvSpeedStpt.value, nviDrvSpeedScale and SCPT\_nomFreq.

Frequency command (Hz) = nviDrvSpeedStpt.value (%) x nviDrvSpeedScale (%) x SCPT\_nomFreq (Hz)

Each time any one of the three terms in the above equation is entered, the interface card calculates the frequency command again and overwrites the previous value with new one, regardless of whether the inverter is running or on halt. If state = 0xFF, however, no recalculation takes place even with any input.

 **Note** The frequency command can be specified with this NV and nv9 nviFrecmd. If both of these NVs are specified, the last one takes effect on the inverter (Last command has priority).

 **Tip** To enable the inverter's run/stop and frequency commands via the LONWORKS network, either of the following settings is required.

UCPT\_LinkFunc = 3 or inverter's function code y98 = 3

- CPs for control of the affected network bandwidth: SCPT\_maxRcvTime

### (2) nv2 nviDrvSpeedScale

This NV specifies the motor rotational direction and frequency command.

- Variable type: SNVT\_lev\_percent

- Data setting range: -163.840 to 163.830% (0.005% resolution)

If entering 163.835% (invalid), for example, the interface card ignores the entry and the inverter runs with the previous value.

- Default setting: Value specified by SCPT\_defScale

- CPs for control of the affected network bandwidth: SCPT\_maxRcvTime

**(3) nv8 nviOpecmd**

This NV specifies the inverter data of run forward/reverse, digital input terminals [X1] to [X9], [FWD] and [REV]. The command format of this NT is the same as that of function code S06.

bit 15	bit 14	bit 13	bit 12	bit 11	bit 10	bit 9	bit 8	bit 7	bit 6	bit 5	bit 4	bit 3	bit 2	bit 1	bit 0
ALM RST	[REV]	[FWD]	-	-	X9	X8	X7	X6	X5	X4	X3	X2	X1	REV	FWD

FWD, REV: Run forward/reverse commands to the inverter

X1 to X9: Terminal command assignment fields for inverter's digital inputs [X1] to [X9]

[FWD], [REV]: Run forward/reverse terminal command assignment fields for inverter's digital inputs [FWD] and [REV]

ALMRST: Switching from ON to OFF clears inverter alarms.

- Variable type: SNVT\_state

- Default setting: 0000000000000000 (16 bit binary)

- CPs for control of the affected network bandwidth: SCPT\_maxRcvTime

 **Note** The number of inverter's general-purpose input terminals differs depending on the target inverter.

 **Tip** To validate this NV entry on the inverter, any of the following settings is required.  
UCPT\_LinkFunc = 2 or 3, or inverter's function code y98 = 2 or 3

**(4) nv9 nviFreqcmd**

This NV specifies the frequency command in Hz with 0.1 Hz resolution.

- Variable type: SNVT\_freq\_hz

- Data setting range: 0.0 to 6553.5 Hz (Valid range for inverter: 0.0 to 400.0 Hz)

- Default setting: 0.0 Hz

- CPs for control of the affected network bandwidth: SCPT\_maxRcvTime

 **Note** The frequency command can be specified with this NV and nv1 nviDrvSpeedStpt. If both of these NVs are specified, the last one takes effect on the inverter (Last command has priority).

 **Tip** To validate this NV entry on the inverter, any of the following settings is required.  
UCPT\_LinkFunc = 1 or 3, or inverter's function code y98 = 1 or 3

**(5) nv10 nviReadParamCode**

This NV specifies a target inverter's function code to read out its data with nv33 nvoReadParamVal.

 For details about readout of function code data, refer to Section 7.6.1 "Reading from inverter's function codes."

- Variable type: SNVT\_count

- Data setting range: 0000 to FFFF (hexadecimal)

- Default: 0000 (hexadecimal)

- CPs for control of the affected network bandwidth: None



**(6) nv11 nviWriteParaCode, nv12 nviWriteParamVal**

Data contained in nv12 will be written into a function code specified by nv11.

 For details about writing data, refer to Section 7.6.2 "Writing to inverter's function codes."

- Variable type: SNVT\_count
- Data setting range: 0000 to FFFF (hexadecimal)
- Default setting: 0000 (hexadecimal)
- CPs for control of the affected network bandwidth: None

**(7) nv13 nviAOcmd**

This NV outputs its value onto the inverter's analog output terminal [FMA/FMP/FMI] (same as universal AO).

To terminal [FM1], the NV outputs 0 to 11 VDC or 4 to 20 mADC. To terminal [FM2], the NV outputs 0 to 11 VDC or 0 to 20 mADC. To terminal [FMA], the NV outputs 0 to 11 VDC or 4 to 20 mADC. To terminal [FMP], it outputs a square wave pulse train prescribed by the inverter. For [FMI], it outputs 4 to 20 mADC.

This allows the inverter to work as an analog output device having a single channel, physical analog output.

 For details about terminals [FMA] and [FMP] (or [FMI] and [FM2]), refer to the user's manual of an inverter, "Wiring for control circuit terminals" and "Overview of Function Codes," F31 and F35.

- Variable type: SNVT\_lev\_percent
- Data setting range: -163.840 to 163.830% (Valid range for inverter: 0.000 to 110.000%)  
Setting 163.835% (invalid), for example, will be ignored so that the inverter runs with the previous value.
- Default setting: 0.000%
- CPs for control of the affected network bandwidth: SCPT\_maxRcvTime

 **Tip** To validate this NV entry on the inverter, either of the following settings is required.

For [FM1] or [FMA], inverter's function code F31 = 10

For [FM2] or [FMP] (or [FMI]), F35 = 10

It is possible to enable both [FM1] and [FM2] or [FMA] and [FMP], however, both terminals output the same analog level signals.

**(8) nv14 nviDOcmd\_Y1, nv15 nviDOcmd\_Y2**

The nv14 or nv15 outputs its ON/OFF value onto inverter's digital output terminal [Y1] or [Y2], respectively (same as universal DO). This allows the inverter's physical Y terminals to work as a 2-bit (max.) digital output device.

 For details about Y terminals, refer to the user's manual of an inverter, "Wiring for control circuit terminals" and "Overview of Function Codes," E20 and E21.

- Variable type: SNVT\_switch
- Data setting range: value = 0.0 to 100.0%, state = 1, 0, -1
- Default settings: value = 0.0%, state = 0
- CPs for control of the affected network bandwidth: SCPT\_maxRcvTime

 **Note** Do not use nviDOcmd\_Y1 or nviDOcmd\_Y2 as a bit array. This is because, in LONWORKS communication, two or more variables are never output concurrently, so the interface card may miss-fetch the bit array at the timing when the data gets validated on the inverter. Accordingly, the inverter could receive it as unexpected data. To handle them as a bit array, read out S07 by the function code readout feature.

 **Tip** To validate this NV entry on the inverter, either of the following settings is required.

For [Y1], inverter's function code E20 = 27

For [Y2], E21 = 27

**(9) nv16 nviFWDcmd**

This NV controls the ON/OFF of inverter's digital input terminal [FWD]. Command assignment to [FWD] is made with function code E98. The factory default command is "Run forward."

 For details about function code E98, refer to the user's manual of an inverter, "FUNCTION CODES."

- Variable type: SNVT\_switch
- Data setting range: value = 0.0 to 100.0%, state = 1, 0, -1
- Default setting: value = 0.0%, state = 0
- CPs for control of the affected network bandwidth: SCPT\_maxRcvTime

 **Note** To assign the "Run reverse" command to terminal [FWD], it is necessary to assign a terminal command other than "Run reverse" to terminal [REV] using function code E99.

 **Note** The run command issued by this NV is independent of the one issued by nviDrvSpeedStpt, so turning ON either one of those run commands runs the motor. To stop it, therefore, concurrently turn OFF both of them issued by the two NVs.

 **Tip** To validate this NV entry on the inverter, any of the following settings is required. UCPT\_LinkFunc = 2 or 3, or inverter's function code y98 = 2 or 3

**(10) nv17 to nv21 nviXcmd\_1 to nviXcmd\_5**

These NVs control the ON/OFF of inverter's digital input terminals [X1] to [X5]. Command assignments to [X1] to [X5] are made with function codes E01 to E05, respectively.

 For details about function codes E01 to E05, refer to the user's manual of an inverter, "FUNCTION CODES."

- Variable type: SNVT\_switch
- Data setting range: value = 0.0 to 100.0%, state = 1, 0, -1
- Default settings: value = 0.0%, state = 0
- CPs for control of the affected network bandwidth: SCPT\_maxRcvTime

 **Note** Do not use any of nviXcmd\_1 to nviXcmd\_5 as a bit array (e.g., multistep speed command). This is because, in LONWORKS communication, two or more variables are never input concurrently, so the interface card may miss-fetch the bit array at the timing when the data gets validated on the inverter. Accordingly, the inverter could transmit it as unexpected data. To handle them as a bit array, use nv8 nviOpecmd, instead.

 **Note** Depending on the command assignment to inverter's digital input terminals, some ON/OFF commands via the LONWORKS network using these NVs may be ignored. On the other hand, some commands entered from the terminal block may be unconditionally validated. For details about these events, refer to the RS-485 Communication User's Manual (MEH448), Chapter 5, Section 5.1.2 [3] "Operation command data."

 **Tip** To validate this NV entry on the inverter, any of the following settings is required UCPT\_LinkFunc = 2 or 3, or inverter's function code y98 = 2 or 3

**(11) nv22 nviAlarmReset**

Setting the ON value to this NV releases the inverter's trip state. If any alarm factor persists at the entry of the ON value, the trip state cannot be released. After the entry of the ON value, the NV state automatically reverts to OFF.

- Variable type: SNVT\_switch
- Data setting range: value = 0.0 to 100.0%, state = 1, 0, -1
- Default setting: value = 0.0%, state = 0
- CPs for control of the affected network bandwidth: None

## 7.5 VSD Object Output Network Variables

This section describes VSD object output network variables that need supplemental explanations. For variables not found in this section, refer to Section 7.3 "VSD Object."

### (1) nv4 nvoDrvSpeed

This NV outputs the inverter's output frequency as a percentage of SCPT\_nomFreq (Base frequency).

- Variable type: SNVT\_lev\_percent
- Data setting range: -163.840 to 163.830% (0.005% resolution)
- CPs for control of the affected network bandwidth: SCPT\_maxSendTime, SCPT\_minSendTime and SCPT\_minDeltaLevel
- Output timing: At the time of data change, at intervals specified by SCPT\_maxSendTime (if specified), after the time specified by SCPT\_minSendTime (if specified), or when the data change rate exceeds the value specified by SCPT\_minDeltaLevel (if specified)

### (2) nv23 nvoDrvStatus

This NV outputs the current inverter status. The format of this NV is the same as that of the inverter's communication function code M14.

bit 15 bit 14 bit 13 bit 12 bit 11 bit 10 bit 9 bit 8 bit 7 bit 6 bit 5 bit 4 bit 3 bit 2 bit 1 bit 0

BUSY	-	-	RL	ALM	DEC	ACC	IL	VL	-	NUV	BRK	INT	EXT	REV	FWD
------	---	---	----	-----	-----	-----	----	----	---	-----	-----	-----	-----	-----	-----

- |                                                         |                                       |
|---------------------------------------------------------|---------------------------------------|
| FWD, REV : Run forward, Run reverse                     | IL : During output current limiting   |
| EXT : During DC-braking (or Pre-exciting)               | ACC : During acceleration             |
| INT : Inverter shutdown                                 | DEC : During deceleration             |
| BRK : Braking                                           | ALM : Alarm relay output              |
| NUV : DC link bus voltage established (0: Undervoltage) | RL : Communication active             |
| VL : Output voltage limiting                            | BUSY : Busy in writing function codes |

- Variable type: SNVT\_state
- CPs for control of the affected network bandwidth: SCPT\_maxSendTime and SCPT\_minSendTime
- Output timing: At the time of data change, at intervals specified by SCPT\_maxSendTime (if specified), or after the time specified by SCPT\_minSendTime (if specified)

### (3) nv33 nvoReadParamVal

This NV reads out data from the inverter's function code specified by nv10 nviReadParamCode.

 For details about readout of function code data, refer to Section 7.6.1 "Reading from inverter's function codes."

- Variable type: SNVT\_count
- Data setting range: 0000 to FFFF (hexadecimal)
- CPs for control of the affected network bandwidth: SCPT\_maxSendTime
- Output timing: At the input time of nv10 nviReadParamCode or at intervals specified by SCPT\_maxSendTime (if specified)

 This NV is issued after input of nviReadParamCode, regardless of whether the data has been changed or not.

**(4) nv34 nvoAccessErrCode**

After completion of writing of inverter's function code data with nv11 nviWriteParaCode and nv12 nviWriteParamVal, this NV outputs a three-byte string "Write error code (1 byte) + Function code accessed (2 bytes)." If the data has been successfully written, the error code value is 00h.

For details about error codes, refer to Table 7-10 in Section 7.6.2 "Writing to inverter's function codes."

- Variable type: UNVT\_ErrCode (3 bytes)

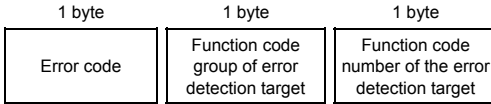

**Note** LonMaker represents this NV data in the format: "Error code (decimal), Function code group (decimal), Function code number (decimal)."

For details about the NV format and function code writing procedure, refer to Section 7.6.2 "Writing to inverter's function codes."

- Data setting range: 00, 00, 00 to FF, FF, FF (hexadecimal)
- CPs for control of the affected network bandwidth: None
- Output timing: After the input time of nv12 nviWriteParamVal

**(5) nv35 to nv37 nvoAIVal\_1 to nvoAIVal\_3**

The nv35 to nv37 output the voltage or current input level applied to inverter's analog input terminals [12], [C1] and [V2] in percentage, respectively. Table 7-7 lists the relationship between terminals and NVs.

Table 7-7 Analog input terminals and NVs

Network variables	Analog terminals	Analog signal level
nvoAIVal_1	[12]	0 to 100% = 0 to 10 V
nvoAIVal_2	[C1]	0 to 100% = 4 to 20 mA or 0 to 20 mA
nvoAIVal_3	[V2]	0 to 100% = 0 to 10 V

For details about terminals [12], [C1] and [V2], refer to the "Wiring for control circuit terminals" in the Inverter User's Manual.

- Variable type: SNVT\_lev\_percent
- Data setting range: 0.000 to 100.000% (0.005% resolution)
- CPs for control of the affected network bandwidth: SCPT\_maxSendTime, SCPT\_minSendTime, SCPT\_minDeltaLevel
- Output timing: At the time of data change, at intervals specified by SCPT\_maxSendTime (if specified), after the time specified by SCPT\_minSendTime (if specified), or when the data change rate exceeds the value specified by SCPT\_minDeltaLevel (if specified)

**Note** The NV ignores bias and gain data for each analog input. On the LONWORKS network, the following relationship is always established regardless of the bias and gain data: When 0 V (0 mA or 4 mA) is applied to an analog input terminal, the NV value is 0%, and when 10 V (or 20 mA), 100%.

## (6) nv38 nvoPIDFb

When the PID feedback value is assigned to any of analog input terminals [I2], [C1] and [V2], this NV outputs the analog signal level applied to that terminal as the PID feedback value in percentage.



To use this NV, it is necessary to enable the inverter's PID control. For details about the PID control of the inverter, refer to the "J codes" and "PID Control Block" given in the Inverter User's Manual.

- Variable type: SNVT\_lev\_percent
- Data setting range: 0.0 to 163.830% (0.005% resolution)
- CPs for control of the affected network bandwidth: SCPT\_maxSendTime, SCPT\_minSendTime, SCPT\_minDeltaLevel
- Output timing: At the time of data change, at intervals specified by SCPT\_maxSendTime (if specified), after the time specified by SCPT\_minSendTime (if specified), or when the data change rate exceeds the value specified by SCPT\_minDeltaLevel (if specified)



This NV data can be adjusted with analog input gain setting. The related inverter's function codes are C32, C34, C37, C39, C42 and C44.

## (7) nv39, nv40, nv41, nv43 nvoYstatus\_1, nvoYstatus\_2, nvoYstatus\_3, nvoYstatus\_5

The nv39 to nv41 and nv43 output the ON/OFF status of inverter's digital output terminals [Y1] to [Y3] and relay contact output terminal [5A/C], respectively. Signal assignments to these terminals are made with function codes E20 to E22 and E24.



For details about function codes E20, E21, E22 and E24, refer to the user's manual of an inverter, "FUNCTION CODES."

- Variable type: SNVT\_switch
- Data setting range: value = 0.0, 100.0%, state = 1, 0
- CPs for control of the affected network bandwidth: SCPT\_maxSendTime, SCPT\_minSendTime
- Output timing: At the time of data change, at intervals specified by SCPT\_maxSendTime (if specified) or after the time specified by SCPT\_minSendTime (if specified)



Although the nv42 nvoYstatus\_4 exists, it does not function since the Inverter does not support terminal [Y4].

## (8) nv44 to nv48 nvoXstatus\_1 to nvoXstatus\_5

The nv44 to nv48 check whether terminal commands applied to inverter's digital input terminals [X1] to [X9] are validated or not on the inverter, respectively, and outputs it in ON/OFF state.



Setting data "0" to inverter's function code y98 or UCPT\_LinkFunc makes it possible to monitor the validation status of terminal commands applied to physical terminals [Xn], respectively. In this situation, it is also possible to monitor commands assigned by nviXcmd\_1 to nviXcmd\_5 as well.

For details, refer to the RS-485 Communication User's Manual (MEH448), Chapter 5, Section 5.1.2 [3] "Operation command data."

- Variable type: SNVT\_switch
- Data setting range: value = 0.0, 100.0%, state = 1, 0
- CPs for control of the affected network bandwidth: SCPT\_maxSendTime, SCPT\_minSendTime
- Output timing: At the time of data change, at intervals specified by SCPT\_maxSendTime (if specified) or after the time specified by SCPT\_minSendTime (if specified)



Assigning "Universal DI" to a digital input terminal (E01 to E05 = 25) makes it possible to output the physical ON/OFF status of terminal [Xn] onto the LONWORKS network. Accordingly, the inverter's physical terminal [Xn] can be used as a digital input device having max. 5 bits.



Depending on the command assignment to inverter's digital input terminals, some ON/OFF commands via the LONWORKS network using these NVs may be ignored. On the other hand, some commands entered from the terminal block may be unconditionally validated. For details about these events, refer to the RS-485 Communication User's Manual (MEH448), Chapter 5, Section 5.1.2 [3] "Operation command data."

**(9) nv50 nvoAlarm**

This NV outputs the contents of an alarm that is occurring or has recently occurred.

- Variable type: UNVT\_alarm\_cod (1 byte, decimal)
- Data setting range: 0 to 255
- CPs for control of the affected network bandwidth: SCPT\_minSendTime
- Output timing: At the time of data change or after the time specified by SCPT\_minSendTime (if specified)

Table 7-8 Alarm Code Table

Alarm codes in M16 to M19	Description		Alarm codes in M16 to M19	Description	
0 (00 <sub>H</sub> )	No alarm	---	23 (17 <sub>H</sub> )	Overload of motor 1	OL1
1 (01 <sub>H</sub> )	Overcurrent (during acceleration)	OL1	24 (18 <sub>H</sub> )	Overload of motor 2	OL2
2 (02 <sub>H</sub> )	Overcurrent (during deceleration)	OL2	44 (2C <sub>H</sub> )	Overload of motor 3	OL3
3 (03 <sub>H</sub> )	Overcurrent (During running at constant speed)	OL3	45 (2D <sub>H</sub> )	Overload of motor 4	OL4
5 (05 <sub>H</sub> )	Grounding fault	EF	25 (19 <sub>H</sub> )	Inverter overload	OLL
6 (06 <sub>H</sub> )	Overvoltage (during acceleration)	OU1	27 (1B <sub>H</sub> )	Over speed error	OS
7 (07 <sub>H</sub> )	Overvoltage (during deceleration)	OU2	28 (1C <sub>H</sub> )	Wiring break in a PG	PG
8 (08 <sub>H</sub> )	Overvoltage (during running at constant speed or stopped)	OU3	29 (1D <sub>H</sub> )	Wiring break in a NTC thermistor	ntb
10 (0A <sub>H</sub> )	Undervoltage	LU	31 (1F <sub>H</sub> )	Memory error	Er1
11 (0B <sub>H</sub> )	Input phase loss	Li n	32 (20 <sub>H</sub> )	Keypad communications error	Er2
12 (0C <sub>H</sub> )	Power supply frequency error	FfE	33 (21 <sub>H</sub> )	CPU error	Er3
13 (0D <sub>H</sub> )	AC fuse blown	ACF	34 (22 <sub>H</sub> )	Option communications error	Er4
14 (0E <sub>H</sub> )	Fuse blown	FUS	35 (23 <sub>H</sub> )	Option error	Er5
15 (0F <sub>H</sub> )	DC fuse blown	dCF	36 (24 <sub>H</sub> )	Operation protection	Er6
16 (10 <sub>H</sub> )	Charger circuit fault	PbF	37 (25 <sub>H</sub> )	Tuning error	Er7
17 (11 <sub>H</sub> )	Heat sink overheat	OH1	38 (26 <sub>H</sub> )	RS-485 communications error (COM port 1)	Er8
18 (12 <sub>H</sub> )	External alarm	OH2	53 (35 <sub>H</sub> )	RS-485 communications error (COM port 2)	ErP
19 (13 <sub>H</sub> )	Inverter internal overheat	OH3	39 (27 <sub>H</sub> )	A/D converter deflection	Er9
20 (14 <sub>H</sub> )	Motor protection (PTC/NTC thermistor)	OH4	42 (29 <sub>H</sub> )	Out-of-step detection	Er d
22 (16 <sub>H</sub> )	Braking resistor overheat	dbH	46 (2E <sub>H</sub> )	Output phase loss	OPL

Table 7-8 Alarm Codes (Continued)

Alarm codes in M16 to M19	Description		Alarm codes in M16 to M19	Description	
47 (2F <sub>H</sub> )	Speed mismatching (Out of speed control)	<i>E-rE</i>	91 (5B <sub>H</sub> ) 92 (5C <sub>H</sub> ) 93 (5D <sub>H</sub> )	Feedback error Exterior PID1 Exterior PID2 Exterior PID3	<i>PLA</i> <i>PLB</i> <i>PLC</i>
50 (32 <sub>H</sub> )	Magnetic pole sensor error	<i>E-rC</i>			
51 (33 <sub>H</sub> )	Data save error during undervoltage	<i>E-rF</i>			
52 (34 <sub>H</sub> )	Position deviation error	<i>dD</i>	250 (FA <sub>H</sub> )	Low battery	<i>Lab</i>
54 (36 <sub>H</sub> )	Hardware error	<i>E-rH</i>	251 (FB <sub>H</sub> )	Time information loss	<i>dL</i>
56 (38 <sub>H</sub> )	Position control error	<i>E-ro</i>	252 (FC <sub>H</sub> )	Forced operation	<i>Fod</i>
57 (39 <sub>H</sub> )	Enable circuit error	<i>E-rF</i>	253 (FD <sub>H</sub> )	Password protection	<i>LoP</i>
58 (3A <sub>H</sub> )	Current input disconnect detection	<i>C-oF</i>	254 (FE <sub>H</sub> )	Mock alarm	<i>E-rr</i>
59 (3B <sub>H</sub> )	DB transistor failure	<i>dBr</i>			
65 (41 <sub>H</sub> )	Customizable logic error	<i>E-rL</i>			
66 (42 <sub>H</sub> )	PID1 feedback error	<i>PL1</i>			
67 (43 <sub>H</sub> )	PID2 feedback error	<i>PL2</i>			
68 (44 <sub>H</sub> )	USB communications error	<i>E-rU</i>			
81 (51 <sub>H</sub> )	Drought protection	<i>P-dr</i>			
82 (52 <sub>H</sub> )	Control of maximum starts per hour	<i>r-oC</i>			
83 (53 <sub>H</sub> )	End of curve protection	<i>P-dL</i>			
84 (54 <sub>H</sub> )	Anti jam	<i>rLo</i>			
85 (55 <sub>H</sub> )	Filter clogging error	<i>F-oL</i>			

**(10) nv51 nvoAlarmLog**

This NV outputs the history of recent 3 alarms.

- Variable type: UNVT\_alarm\_log (Decimal, 1 byte x 3)

1 byte	1 byte	1 byte
Most recent alarm code (Decimal)	2nd recent alarm code (Decimal)	3rd recent alarm code (Decimal)

**Note** LonMaker represents this NV data in the format: "Most recent alarm code, 2nd recent alarm code, 3rd recent alarm code."

- Data setting range: 0, 0, 0 to 255, 255, 255

- CPs for control of the affected network bandwidth: SCPT\_minSendTime

- Output timing: At the time of data change or after the time specified by SCPT\_minSendTime (if specified)

## 7.6 Reading and Writing from/to Inverter's Function Codes

### 7.6.1 Reading from inverter's function codes

Use nv10 nviReadParamCode and nv33 nvoReadParamVal. This section summarizes the reading procedure.

- Enter the inverter's target function code into nv10 nviReadParamCode in the 16-bit format shown below. This starts the readout process of the inverter's function code.

(Example) Reading H30 from the inverter

H: Function code group 08  
 30: 1E (hexadecimal) } 081E (hexadecimal) = 2078 (decimal)

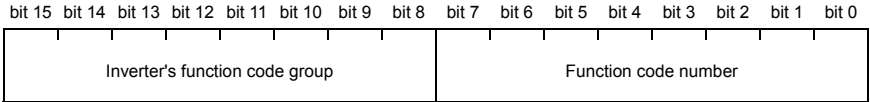

Inverter's function code group: Group of function codes (F, E, C etc.). See Table 7-9 below.

Function code number: 2-digit number following the function code group. For example, 98 in E98.

- nv33 nvoReadParamVal outputs the data of the function code specified by nv10 nviReadParamCode, then the readout process terminates. The value is subject to the format of individual function codes.

For details about the data format of individual function codes, refer to the RS-485 Communication User's Manual (MEH448), Chapter 5, Section 5.2 "Data Formats."

**Tip** Input of a non-existing function code returns "0" to nv33 nvoReadParamVal.

**Note** If a running readout process for a function code is interrupted by another readout request, the interrupting request will be ignored. This interface card does not support any output NV that identifies whether a readout process is already running. To run the read process very frequently, therefore, it is recommended that the software be so designed that it monitors the input/output status of nv10 nviReadParamCode and nv33 nvoReadParamVal, confirms the completion of all the previous processes, and then starts a new readout process.

Table 7-9 Function Code Groups

Classification	Group number	Function code name	Classification	Group number	Function code name		
S	2	02h	Command Data	W1	23	17h	Monitor 3
M	3	03h	Monitor Data	W2	24	18h	Monitor 4
F	4	04h	Fundamental Functions	W3	25	19h	Monitor 5
E	5	05h	Extension Terminal Functions	X1	26	1Ah	Alarm 3
C	6	06h	Control Functions	X2	27	1Bh	Alarm 4
P	7	07h	Motor 1 Parameters	Z1	28	1Ch	Alarm 5
H	8	08h	High Performance Functions	K	29	1Dh	Keypad Panel Function
A	9	09h	Motor 2 Parameters	T	30	1Eh	Clock Timer Function
o	10	0Ah	Optional Functions	E1	31	1Fh	Extension Terminal Functions 1
L	11	0Bh	For elevators	H1	32	20h	High Performance Function 1
r	12	0Ch	Motor 4 Parameters	o1	33	21h	Optional Functions 1
U	13	0Dh	Soft relay 1	U1	34	22h	Soft relay 2
J	14	0Eh	Application Function 1	M1	35	23h	Monitor Data 1
y	15	0Fh	Link Functions	J1	36	24h	Application Function
W	16	10h	Monitor Data 2	J2	37	25h	Application Function
X	17	11h	Alarm Data 1	J3	38	26h	Application Function
Z	18	12h	Alarm Data 2	J4	39	27h	Application Function
b	19	13h	Motor 3 Parameters	J5	40	28h	Application Function
d	20	14h	Application Functions 2	J6	41	29h	Application Function
				d1	42	24Ah	Application Function



Example: F26      F ⇒ Group number 04  
                  26 ⇒ 1A (16 notation) } "04 1A"

Example: Reading the inverter's function code F23 (Starting frequency) whose value is 0.5 Hz

- 1) nv10 nviReadParamCode: Enter 417 (hex) to this NV.  
                                  Function code group = F (04h), Function code number = 23 (17h)
- 2) nv33 nvoReadParamVal: This NV outputs 5.  
                                  (5 means 0.5 Hz because of the format with 0.1 Hz resolution)

**7.6.2 Writing to inverter's function codes**

Use nv11 nviWriteParamCode, nv12 nviWriteParamVal, and nv34 nvoAccessErrCode. This section summarizes the writing procedure.

- (1) Enter the inverter's target function code into nv11 nviWriteParamCode. The data entry format is the same as that of the readout on the previous page.
- (2) Enter data to be written into the target function code, into nv12 nviWriteParamVal. This starts the writing process of the function code data to the inverter. The data entry format is the same as that of the readout on the previous page.

 For details about the data format of individual function codes, refer to the RS-485 Communication User's Manual (MEH448), Chapter 5, Section 5.2 "Data Formats."

- (3) nv34 nvoAccessErrCode outputs the result of the writing process, then the writing process terminates. The format of nv34 nvoAccessErrCode is shown below.

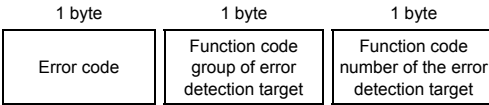

 **Note** LonMaker represents this NV data in the format: "Error code (decimal), Function code group (decimal), Function code number (decimal)."



 Function code groups are the same as those in the readout process. See Table 7-9.

Table 7-10 Error Codes

Error code	Description
00h (0)	Normal
01h (1)	Link priority error
02h (2)	Attempted to write data to a non-existing function code
03h (3)	Attempted to write data to a write-protected function code
06h (6)	Attempted to write data to a function code not allowed to change during running
07h (7)	Attempted to write data to a function code not allowed to change when the terminal input is alive.
08h (8)	Out of data entry range
09h (9)	Attempted to write data to a password-protected function code
0Fh (15)	Function code write error

 **Note** If a writing process for a function code is interrupted by another writing request, error code 0Fh (Function code write error) is immediately issued to nv34 nvoAccessErrCode as a response to the interrupting request, then the response to the interrupted process will be issued.

Example: Writing 9.5 s to the inverter's function code H13 (Restart Mode after Momentary Power Failure, Restart time)

- 1)nv11 nviWriteParamCode: Enter 80Dh to this NV.  
Function code group = H (08h), Function code number = 13 (0Dh)
- 2)nv12 nviWriteParamVal: Enter 95 to this NV.  
(95 means 9.5 seconds because of the format with 0.1 s resolution)
- 3)nv34 nvoAccessErrCode: The written result is returned to this NV as the following strings.
  - For normal writing: 0, 8, 13 (0: Error code, H: Function code group, 13: Function code number)
  - For out of range writing: 8, 8, 13(8: Error code, H: Function code group, 13: Function code number)

ENGLISH

## 7.7 VSD Object Configuration Properties (CPs)

This section details VSD object configuration properties (CPs) that need supplemental descriptions. For CPs not found in this section, refer to Section 7.3 "VSD Object."

### (1) SCPT\_maxRcvTime

Receive heartbeat. This CP specifies the heartbeat receive interval for input NVs listed in Table 7-11 in block. If no data is received within this interval after the reception of the last data, the interface card interprets the state as a LONWORKS communications error.

Setting the heartbeat time at 0.0 s does not break the connection to the LONWORKS network even if no data is received.

 For details about the settings and activities on a LONWORKS connection break, refer to Chapter 8, Section 8.1 "Specifying an Inverter Reaction to LONWORKS Communications Errors."

- Data setting range: 0.0 to 6553.4 s (0.1 s resolution)

- Default setting: 0.0 s (Ignore connection break)

 **Note** Writing a value (e.g., 6553.5) exceeding the data setting range to this CP displays the value but does not update the internal value, retaining the previously written data.

Table 7-11 NVs with Receive Heartbeat Time Specified by SCPT\_maxRcvTime

Index	NV name
nv1	nviDrvSpeedStpt
nv2	nviDrvSpeedScale
nv8	nviOpeCmd
nv9	nviFreqCmd
nv13	nviAOCmd
nv14, nv15	nviDOcmd_Y1, Y2
nv16	nviFWDcmd
nv17 to nv21	nviXcmd_1 to 5

### (2) SCPT\_maxSendTime

Send heartbeat. This CP specifies the constant updating period for all output NVs listed in Table 7-12 below in block. Specifying it periodically updates those NVs that include the internal monitor values.

Setting the send heartbeat at 0.0 s does not cause updating.

- Data setting range: 0.0 to 6553.4 s (0.1 s resolution)

- Default setting: 0.0 s (No periodic updating)

Table 7-12 NVs with Send Heartbeat Time Specified by SCPT\_maxSendTime

Index	NV name	Index	NV name
nv3	nvoDrvCurrt	nv32	nvoDrvTemp_2
nv4	nvoDrvSpeed	nv33	nvoReadParamVal
nv5	nvoDrvVolt	nv35	nvoAiVal_1
nv6	nvoDrvPwr	nv36	nvoAiVal_2
nv23	nvoOpeStatus	nv37	nvoAiVal_3
nv24	nvoOutputFreq	nv38	nvoPIDFb
nv25	nvoDrvTorque	nv39 to nv43	nvoYstatus_1 to 5
nv26	nvoDrvEnergy	nv44 to nv48	nvoXstatus_1 to 5
nv31	nvoDrvTemp_1		

**(3) SCPT\_minSendTime**

Minimum pause period for send. This CP specifies the send prohibit time length for all output NVs listed in Table 7-13 in block. Until this time has elapsed, the interface card does not output any NVs even if the NV value changes within this time length.

Setting this CP at 0.0 s provides no send prohibit time length.

- Data setting range: 0.0 to 6553.4 s (0.1 s resolution)

- Default setting: 0.0 s (Inactive)

Table 7-13 NVs with Minimum Pause Period Specified by SCPT\_minSendTime

Index	NV name
<b>All output NVs except the following</b>	
nv33	nvoReadParamVal
nv34	nvoAccessErrCode

**(4) SCPT\_minDeltaLevel**

Minimum data change rate for send. This CP specifies the hysteresis width or minimum insensitivity band on data change for individual NVs listed in Table 7-14. If a data change exceeding the band occurs in an NV, the NV can fetch the change in its data and the interface card outputs it.

Specify the band in the ratio (%) to the 100% value of each NV value. Table 7-14 lists the 100% value of each NV.

Setting 0.0% also inactivates this CP.

- Data setting range: 0.0 to 200.0% (0.5% resolution)

- Default setting: 0.0% (Inactive)

Table 7-14 NVs with Minimum Data Change Rate Specified by SCPT\_maxSendTime

Index	NV name	Unit	100% value
nv3	nvoDrvCurmt	A	Rated output current of the inverter
nv4	nvoDrvSpeed	%	100%
nv5	nvoDrvVolt	V	Base voltage. Same as data of inverter's function code F05. When F05 = 0 (not AVR-controller), 200/400 VAC.
nv6	nvoDrvPwr	kW	Capacity of the inverter
nv24	nvoOutputFreq	Hz	Value specified by SCPT_nomFreq
nv25	nvoDrvTorque	%	100%
nv30	nvoDCbusCapacity	%	100%
nv31	nvoDrvTemp_1	°C	100°C
nv32	nvoDrvTemp_2	°C	100°C
nv35	nvoAIVal_1	%	100%
nv36	nvoAIVal_2	%	100%
nv37	nvoAIVal_3	%	100%
nv38	nvoPIDFb	%	100%

## Chapter 8 Inverter Reaction to LONWORKS Communications Errors

### 8.1 Specifying an Inverter Reaction to LONWORKS Communications Errors

If, with the receive heartbeat SCPT\_maxRcvTime specified, the target input NV receives no data within the specified heartbeat time, this card interprets it as a LONWORKS communications error (timeout), causing the inverter to trip with *er5* depending upon the configuration.

The inverter reaction to follow an occurrence of LONWORKS communications errors can be specified with the configuration properties (CPs) or their equivalent inverter's function codes given below.

Configuration properties (CPs)	Equivalent inverter's function code
UCPT_CblLossMode	o27
UCPT_CblLossTimer	o28

 For details about input network variables (NVs) to be monitored if a LONWORKS communications error occurs, refer to Table 7-11 in Chapter 7, Section 7.7 "(1) SCPT\_maxRcvTime."

 Such an input NV that has not received data once could not be a timeout monitor target, so no LONWORKS communications error can be detected even if the receive heartbeat SCPT\_maxRcvTime is specified and the input NV receives no data within the specified heartbeat time.

#### (1) UCPT\_CblLossMode

As listed in Table 8-1, this CP specifies the inverter reaction mode to select when a communications error is detected. Inverter's function code o27 is functionally equivalent to this CP. Modifying the CP automatically modifies function code o27 data, and vice versa.

Table 8-1 Specifying Inverter Reaction Mode with UCPT\_CblLossMode

SCPT_maxRcvTime	UCPT_CblLossMode (o27)	UCPT_CblLossTimer (o28)	Inverter Reaction to Communications Errors
0s	-	-	Skip out on time-out. No error indication on LEDs. NV continues the current state.
Other than 0s (Set time-out time)	0, 4 to 9	-	After time-out, immediately the motor coasts to a stop and issuing " <i>E-r-S</i> ".
	1	Delay time	After time-out, the motor coasts to a stop and issuing " <i>E-r-S</i> " after the time longer than the specified timer (o28) period.
	2	Delay time	After time-out, when the data does not input during the time specified timer (o28) period, the motor coasts to a stop and issuing " <i>E-r-S</i> ". If the data input, the communication error is disvalued.
	3, 13 to 15	-	The communication error is disvalued and continues the current behavior. (no " <i>E-r-S</i> " is issued.) NV continues the current state. Minor indication on LEDs (flashing red on POWER LEDs).
	10	-	After time-out, immediately decelerates it to a stop, and after stopped, issuing " <i>E-r-S</i> ".
	11	Delay time	After time-out, decelerates it to a stop after the time longer than the specified timer (o28) period, and after stopped, issuing " <i>E-r-S</i> ".
	12	Delay time	After time-out, when the data does not input during the time specified timer (o28) period, decelerates it to a stop, and after stopped, issuing " <i>E-r-S</i> ". If the data input, the communication error is disvalued.

 Even if a LONWORKS communications error has occurred, the inverter may not display *E-r-S* with the configuration including UCPT\_CblLossMode = 3. However, the POWER LED on the interface card blinks in red, showing an occurrence of LONWORKS communications errors.

 If the network binds only NVs of this card (turnaround connection), the communications link can be established even with the LONWORKS network cable disconnected, so no communications error occurs.

#### (2) UCPT\_CblLossTimer

This CP specifies the timer to work when a communications error is detected. The timer count object varies with the UCPT\_CblLossMode setting as listed in Table 8-1 above. Inverter's function code o28 is functionally equivalent to this CP. Modifying the CP automatically modifies function code o27 data, and vice versa.

## Chapter 9 Troubleshooting

If any problem arises with this card, follow the troubleshooting procedures given below.

No.	Phenomenon/Symptom	Probable Causes
1	None of the LEDs on the interface card would light.	<ul style="list-style-type: none"> <li>• The inverter is not powered ON.</li> <li>• The card is not properly installed.</li> <li>• The card is faulty.</li> </ul>
2	$E_r-4$ alarm cannot be reset. (The POWER LED lights in red.)	<ul style="list-style-type: none"> <li>• The card is not properly installed.</li> <li>• The card is faulty.</li> </ul>
3	$E_r-5$ alarm cannot be reset. (The POWER LED flashes in red.)	<ul style="list-style-type: none"> <li>• Cabling is not properly done.</li> <li>• The target input NV has not received data within the time specified by the receive heartbeat.</li> </ul>
4	No commissioning possible.	<ul style="list-style-type: none"> <li>• An XIF file designed for different products is used or the XIF file version is not latest.</li> <li>• Cabling is not properly done.</li> <li>• The card is not grounded. (Communication impossible due to noise)</li> </ul>
5	Data entered to NVs or CPs after commissioning cannot be validated on the inverter.	<ul style="list-style-type: none"> <li>• After commissioning of the card, the inverter is not restarted or reset with a LONWORKS integration tool (e.g., LonMaker).</li> <li>• The network is offline or disabled.</li> </ul>
6	Output NV cannot be monitored.	<ul style="list-style-type: none"> <li>• The SCPT_maxSendTime value specified is not greater than the SCPT_minSendTime value specified.</li> <li>• The SCPT_minDeltaLevel value specified is too large so that the change cannot be recognized.</li> <li>• The card is in the waiting time specified by UCPT_SendDelayAfterDevRdy.</li> <li>• The network is offline or disabled.</li> </ul>
7	A run or frequency command cannot be validated on the inverter.	<ul style="list-style-type: none"> <li>• y98 or UCPT_LinkFunc is not set to "3."</li> <li>• Any higher priority run or frequency command is enabled by inverter's function codes (y99, <b>LE</b> or <b>LOC</b> terminal command).</li> <li>• After commissioning of the card, the inverter is not restarted or reset with a LONWORKS integration tool (e.g., LonMaker).</li> <li>• The network is offline or disabled.</li> </ul>
8	Turning nviXcmd_1 to 5 or nviFWDcmd command ON is not validated on the inverter.	<ul style="list-style-type: none"> <li>• y98 or UCPT_LinkFunc is not set to "2" or "3."</li> <li>• Terminals [X1] to [X5] and [FWD] are assigned commands not accessible via the LONWORKS network.</li> </ul>
9	Turning nviDOcmd_Y1 or Y2 ON or entering data to nviAOcmd cannot output it to the inverter terminal.	<ul style="list-style-type: none"> <li>• Universal DO and Universal AO are not assigned to terminals [Y1], [FMI] and [FM2] or [FMA] and [FMP], respectively.</li> </ul>
10	The LONWORKS network cable is not connected to the card, but the COMM LED lights.	Normal operation. No problem.
11	The speed command is validated on the inverter, but the actual motor speed is different from the commanded frequency.	Refer to the user's manual of an inverter, "Motor is running abnormally."

## Chapter 10 Specifications

### 10.1 General Specifications

For the items not covered in this section, the specifications of the inverter apply.

Item	Specifications
Model	OPC-LNW
Operating ambient temperature range	-10 to +50°C (Temperature around the inverter)
Operating ambient humidity range	5 to 95% RH (There shall be no condensation.)
External dimensions	98 x 40 mm
Applicable inverter	Check the user's manual of an inverter about an object inverter and a ROM version.

### 10.2 Communications Specifications

Item	Specifications
Transmission speed	78 kbps
Communication IC	FT3120 Smart Transceiver
Transceiver	TP/FT-10 (Free topology)
Network protocol	LonTalk protocol compliant
Network variables (NVs)	62 (including inactive NVs)
Configuration properties (CPs)	28 (including inactive CPs)
Applicable profile	Variable Speed Motor Drive Functional Profile Version 1.1 compliant

**MEMO**



MEMO

**LONWORKS®インタフェースカード / LONWORKS® Interface Card  
"OPC-LNW"**

---

**取扱説明書 / Instruction Manual**

First Edition, August 2013

Fuji Electric Co., Ltd.

---

- 本書の内容については、万全を期して作成いたしました。万が一不審の点や誤り、記載もれなど、お気づきの点がありましたら、ご連絡ください。
- 運用した結果の影響については、上項にかかわらず責任を負いかねますのでご了承ください。

The purpose of this manual is to provide accurate information in the handling, setting up and operating of the LONWORKS® Interface Card for the inverters for our company. Please feel free to send your comments regarding any errors or omissions you may have found, or any suggestions you may have for generally improving the manual.

In no event will Fuji Electric Co., Ltd. be liable for any direct or indirect damages resulting from the application of the information in this manual.

---

## 富士電機株式会社

### パワーエレ機器事業本部

〒141-0032 東京都品川区大崎一丁目 11 番 2 号  
(ゲートシティ大崎イーストタワー)

URL <http://www.fujielectric.co.jp/>

発行 富士電機株式会社 鈴鹿工場

〒513-8633 三重県鈴鹿市南玉垣町 5520 番地

技術相談窓口 TEL:0120-128-220 FAX:0120-128-230

## Fuji Electric Co., Ltd.

Gate City Ohsaki, East Tower, 11-2, Osaki 1-chome,  
Shinagawa-ku, Tokyo, 141-0032, Japan

Phone: +81 3 5435 7283 Fax: +81 3 5435 7425

URL <http://www.fujielectric.com/>