

**English Version**

**ENGLISH**

## Preface

Thank you for purchasing our analog input/output interface card.

This instruction manual describes the analog input/output interface card "OPC-G1-AIO" designed for the FRENIC-MEGA series of inverters.

Mounting the analog input/output interface card on your FRENIC-MEGA enables analog input (voltage and current for each terminal) and analog output (voltage and current for each terminal) to/from the inverter.

The analog input/output interface card can be connected to any one of the three option connection ports (A-, B-, and C-ports) on the FRENIC-MEGA.

This instruction manual does not contain inverter handling instructions. Read through this instruction manual in conjunction with the FRENIC-MEGA Instruction Manual and be familiar with proper handling and operation of this product. Improper handling might result in incorrect operation, a short life, or even a failure of this product.

Keep this manual in a safe place.



### CAUTION

- Read through this instruction manual and be familiar with the analog input/output interface card before proceeding with installation, connections (wiring), operation, or maintenance and inspection.
- Improper handling might result in incorrect operation, a short life, or even a failure of this product as well as the motor.
- Deliver this manual to the end user of this product. Keep this manual in a safe place until this product is discarded.

## ■ Safety precautions

Read this manual thoroughly before proceeding with installation, connections (wiring), operation, or maintenance and inspection. Ensure you have sound knowledge of the device and familiarize yourself with all safety information and precautions before proceeding to operate the inverter.

Safety precautions are classified into the following two categories in this manual.

 <b>WARNING</b>	Failure to heed the information indicated by this symbol may lead to dangerous conditions, possibly resulting in death or serious bodily injuries.
 <b>CAUTION</b>	Failure to heed the information indicated by this symbol may lead to dangerous conditions, possibly resulting in minor or light bodily injuries and/or substantial property damage.

Failure to heed the information contained under the CAUTION title can also result in serious consequences. These safety precautions are of utmost importance and must be observed at all times.

## Installation and wiring

### **WARNING**

- Before starting installation and wiring, turn OFF the power and wait at least five minutes for inverters with a capacity of 22 kW or below, or at least ten minutes for inverters with a capacity of 30 kW or above. Make sure that the LED monitor and charging lamp are turned OFF. Further, make sure, using a multimeter or a similar instrument, that the DC link bus voltage between the terminals P(+) and N(-) has dropped to the safe level (+25 VDC or below).
- Qualified electricians should carry out wiring.

**Otherwise, an electric shock could occur.**

### **CAUTION**

- Do not use the product that is damaged or lacking parts.  
**Doing so could cause a fire, an accident, or injuries.**
- Prevent lint, paper fibers, sawdust, dust, metallic chips, or other foreign materials from getting into the inverter and the option.  
**Otherwise, a fire or an accident might result.**

- Incorrect handling in installation/removal jobs could cause a failure.  
**A failure might result.**

- Noise may be emitted from the inverter, motor and wires. Implement appropriate measure to prevent the nearby sensors and devices from malfunctioning due to such noise.  
**Otherwise, an accident could occur.**

## Operation

### **WARNING**

- Be sure to install the front cover before turning the inverter's power ON. Do not remove the cover when the inverter power is ON.  
**Otherwise, an electric shock could occur.**
- Do not operate switches with wet hands.  
**Doing so could cause an electric shock.**
- If you configure the function codes wrongly or without completely understanding FRENIC-MEGA Instruction Manual and the FRENIC-MEGA User's Manual, the motor may rotate with a torque or at a speed not permitted for the machine. Confirm and adjust the setting of the function codes before running the inverter.  
**Otherwise, an accident could occur.**

## Maintenance and inspection, and parts replacement

### **WARNING**

- Before proceeding to the maintenance/inspection jobs, turn OFF the power and wait at least five minutes for inverters with a capacity of 22 kW or below, or at least ten minutes for inverters with a capacity of 30 kW or above. Make sure that the LED monitor and charging lamp are turned OFF. Further, make sure, using a multimeter or a similar instrument, that the DC link bus voltage between the terminals P(+) and N(-) has dropped to the safe level (+25 VDC or below).  
**Otherwise, an electric shock could occur.**

- Maintenance, inspection, and parts replacement should be made only by qualified persons.
- Take off the watch, rings and other metallic objects before starting work.
- Use insulated tools.

**Otherwise, an electric shock or injuries could occur.**

## Disposal

### CAUTION

- Treat the interface card as an industrial waste when disposing of it.  
**Otherwise injuries could occur.**

## Others

### WARNING

- Never modify the interface card.  
**Doing so could cause an electric shock or injuries.**

## Icons

The following icons are used throughout this manual.



This icon indicates information which, if not heeded, can result in the product not operating to full efficiency, as well as information concerning incorrect operations and settings which can result in accidents.



This icon indicates information that can prove handy when performing certain settings or operations.



This icon indicates a reference to more detailed information.

# Table of Contents

Preface .....	i
■ Safety precautions .....	i
Chapter 1 BEFORE USING THIS OPTION .....	1-1
1.1 Acceptance Inspection .....	1-1
1.2 Applicable Inverters .....	1-2
1.3 Operating Environment .....	1-2
1.4 Installation and Removal of the Interface Card .....	1-2
1.4.1 Installing the interface card .....	1-3
1.4.2 Removing the interface card .....	1-4
1.5 Wiring .....	1-5
1.6 Terminal Allocation and Symbol Diagram .....	1-7
Chapter 2 WIRING .....	2-1
2.1 Connection Diagram .....	2-1
2.2 Terminal Functions .....	2-2
2.3 Configuring Inverter's Function Codes .....	2-4
2.4 Function Codes Details .....	2-6
Chapter 3 I/O CHECKING .....	3-1
Chapter 4 PROTECTIVE FUNCTION .....	4-1

## Chapter 1 BEFORE USING THIS OPTION

### 1.1 Acceptance Inspection

Unpack the package and check the following:

- (1) An interface card, two screws (M3 × 8), and the Analog Input/Output Interface Card Instruction Manual (this manual) are contained in the package.
- (2) The interface card is not damaged during transportation—no defective parts, dents or warps.
- (3) The model name "OPC-G1-AIO" is printed on the interface card. (See Figure 1.1.)

If you suspect the product is not working properly or if you have any questions about your product, contact the shop where you bought the product or your local Fuji branch office.

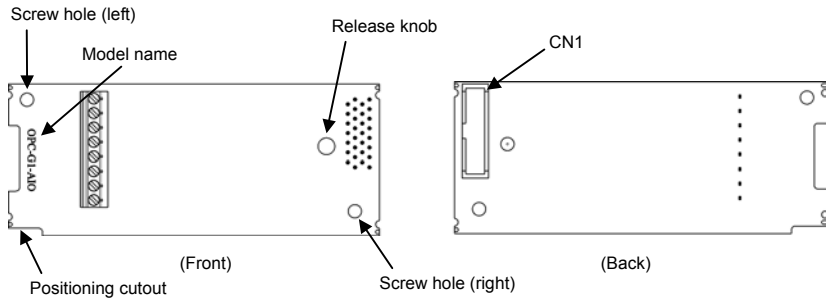

Figure 1.1 Name of Parts on Analog Input/Output Interface Card (OPC-G1-AIO)

## 1.2 Applicable Inverters

This interface card is applicable to the following inverters and ROM version.

Table 1.1 Applicable inverter and ROM version

Series	Inverter type	Applicable motor rating	ROM version
FRENIC-MEGA	FRN□□□G1□-□□□	All capacities	0700 or later

\* The boxes □ replace alphabetic letters depending on the nominal applied motor, enclosure, and power supply voltage.

To check the inverter's ROM version, use Menu #5 "Maintenance Information" on the keypad. (Refer to the FRENIC-MEGA Instruction Manual, Chapter 3, Section 3.4.6 "Reading maintenance information.")

Display on LED Monitor	Item	Description
<i>S_ H</i>	Inverter's ROM version	Shows the inverter's ROM version as a 4-digit code.

## 1.3 Operating Environment

Install the inverter equipped with this interface card in an environment that satisfies the requirements listed in Table 1.2.

Table 1.2 Environmental Requirements

Item	Specifications
Site location	Indoors
Surrounding temperature	Refer to the FRENIC-MEGA Instruction Manual, Chapter 2.
Relative humidity	5 to 95% (No condensation)
Atmosphere	The inverter must not be exposed to dust, direct sunlight, corrosive gases, flammable gases, oil mist, vapor or water drops. Pollution degree 2 (IEC60664-1) (Note) The atmosphere can contain a small amount of salt. (0.01 mg/cm <sup>2</sup> or less per year) The inverter must not be subjected to sudden changes in temperature that will cause condensation to form.
Altitude	1,000 m max.
Atmospheric pressure	86 to 106 kPa
Vibration	Refer to the FRENIC-MEGA Instruction Manual, Chapter 2.

(Note) Do not install the inverter in an environment where it may be exposed to lint, cotton waste or moist dust or dirt which will clog the heat sink of the inverter. If the inverter is to be used in such an environment, install it in a dustproof panel of your system.

## 1.4 Installation and Removal of the Interface Card

 <b>WARNING</b>
<p>Before starting installation and wiring, turn OFF the power and wait at least five minutes for inverters with a capacity of 22 kW or below, or at least ten minutes for inverters with a capacity of 30 kW or above. Make sure that the LED monitor and charging lamp are turned OFF. Further, make sure, using a multimeter or a similar instrument, that the DC link bus voltage between the terminals P(+) and N(-) has dropped to the safe level (+25 VDC or below).</p> <p><b>Otherwise, an electric shock could occur.</b></p>

## ⚠ CAUTION

- Do not use the product that is damaged or lacking parts.  
**Doing so could cause a fire, an accident, or injuries.**
- Prevent lint, paper fibers, sawdust, dust, metallic chips, or other foreign materials from getting into the inverter and the interface card.  
**Otherwise, a fire or an accident might result.**
- Incorrect handling in installation/removal jobs could cause a failure.  
**A failure might result.**

### 1.4.1 Installing the interface card

**Note** Before mounting the interface card, perform the wiring for the main circuit terminals and control circuit terminals.

- (1) Remove the front cover from the inverter and expose the control printed circuit board (control PCB). As shown in Figure 1.2, the interface card can be connected to any one of the three option connection ports (A-, B-, and C-ports) of the inverter.

 To remove the front cover, refer to the FRENIC-MEGA Instruction Manual, Section 2.3. For inverters with a capacity of 30 kW or above, open also the keypad enclosure.

- (2) Insert connector CN1 on the back of the interface card (Figure 1.1) into any of the A-port (CN4), B-port (CN5), and C-port (CN6) on the inverter's control PCB. Then tighten the two screws that come with the card. (Figure 1.4)

**Note** Check that the positioning cutout (shown in Figure 1.1) is fitted on the tab (Ⓢ in Figure 1.3) and connector CN1 is fully inserted (Ⓣ in Figure 1.3). Figure 1.4 shows the interface card correctly mounted.

- (3) Perform wiring on the interface card.

 Refer to Section 1.5 "Wiring."

- (4) Put the front cover back into place.

 To put back the front cover, refer to the FRENIC-MEGA Instruction Manual, Section 2.3. For inverters with a capacity of 30 kW or above, close also the keypad enclosure.

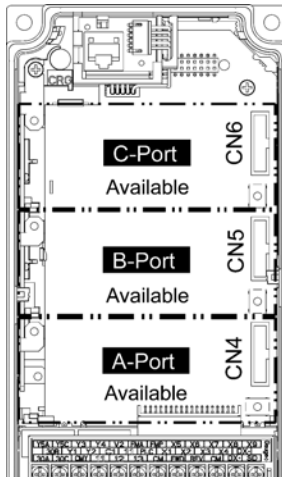
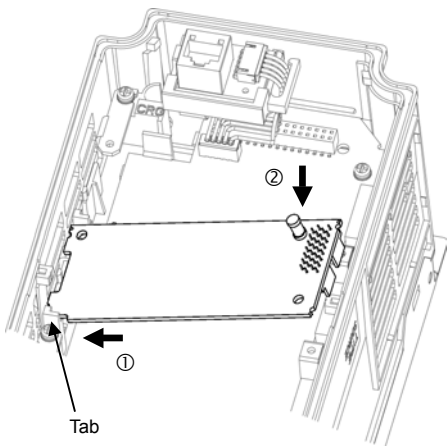

Figure 1.2 In the case of 0.4 kW





- ① Fit the positioning cutout of the card over the tab on the inverter to determine the mounting position.
- ② Insert connector CN1 on the card into any of the three ports (A-, B- and C-ports) on the inverter's control PCB.

Note: Be sure to follow the order of ① and ②. Inserting CN1 first may lead to insufficient insertion, resulting in a contact failure.

Figure 1.3 Mounting the Interface Card (to B-port)

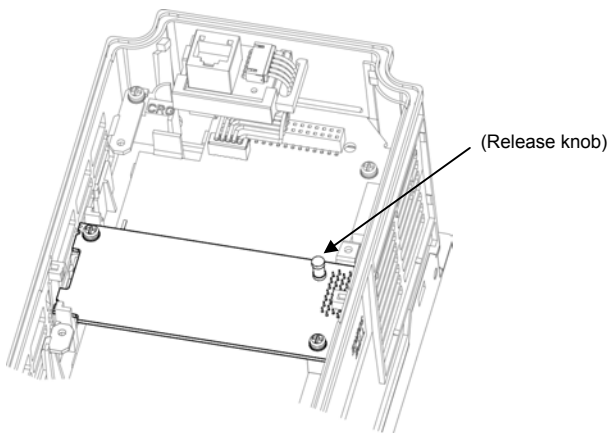

Figure 1.4 Mounting Completed (on B-port)

### 1.4.2 Removing the interface card

Remove the two screws that secure the interface card and pull the release knob (shown above) to take the card out of the inverter.

## 1.5 Wiring

### ⚠ WARNING

- Before starting installation and wiring, turn OFF the power and wait at least five minutes for inverters with a capacity of 22 kW or below, or at least ten minutes for inverters with a capacity of 30 kW or above. Make sure that the LED monitor and charging lamp are turned OFF. Further, make sure, using a multimeter or a similar instrument, that the DC link bus voltage between the terminals P(+) and N(-) has dropped to the safe level (+25 VDC or below).

- Qualified electricians should carry out wiring.

**Otherwise, an electric shock could occur.**

- In general, the covers of the control signal wires are not specifically designed to withstand a high voltage (i.e., reinforced insulation is not applied). Therefore, if a control signal wire comes into direct contact with a live conductor of the main circuit, the insulation of the cover might break down, which would expose the signal wire to a high voltage of the main circuit. Make sure that the control signal wires will not come into contact with live conductors of the main circuit.

**Failure to observe this precaution could cause an electric shock or an accident.**

### ⚠ CAUTION

Noise may be emitted from the inverter, motor and wires.

Take appropriate measures to prevent the nearby sensors and devices from malfunctioning due to such noise.

**An accident could occur.**

Perform wiring for the interface card observing the precautions below. Refer to the connection diagram shown in Figure 2.1 (Chapter 2) and the wiring examples shown in Figure 1.7.

- (1) Turn the inverter's power OFF.
- (2) Use shielded wires.
- (3) To prevent malfunction due to noise, keep the wiring for the interface card away from the main circuit wiring and other power lines as far as possible. Never install them in the same wire duct.
- (4) Complete wiring before turning the inverter ON.
- (5) See Table 1.3 for the specifications of the terminal block on the interface card.

When using stripped wires (without attaching a crimp terminal), strip the wire end by 5 to 7 mm. (Figure 1.5) When using a crimp terminal, attach a vinyl-insulated ferrule.

Loosen the terminal screw, insert the wire end into above the metal part of the terminal block, and tighten the screw to fasten it. (Figure 1.6)

Table 1.3 Terminal Specifications

Item	Specifications
Wire size	AWG24 to AWG18 (0.25 to 0.75 mm <sup>2</sup> ), wire with rated temperature 105°C (UL) recommended
Terminal screw size	M2
Tightening torque	0.22 to 0.25 N·m

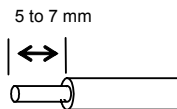

Figure 1.5 Wire End Treatment (For Connection to Terminals on Interface Card)

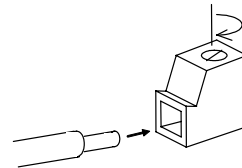

Figure 1.6 Connecting to a Terminal on Interface Card



- Route the wiring of the interface circuit terminals as far from the wiring of the main circuit as possible. Otherwise electric noise may cause malfunctions.
- Fix the interface circuit wires with a cable tie inside the inverter to keep them away from the live parts of the main circuit (such as the terminal block of the main circuit).



Depending upon the wire type and the number of wires used, the front cover may be lifted by the wires, which impedes normal keypad operation. If it happens, change the wire type or size.



Route the wires, taking care not to let them go over the control PCB, as shown in Figure 1.7. Otherwise, malfunctions may occur.

- For inverters with a capacity of 22 kW or below

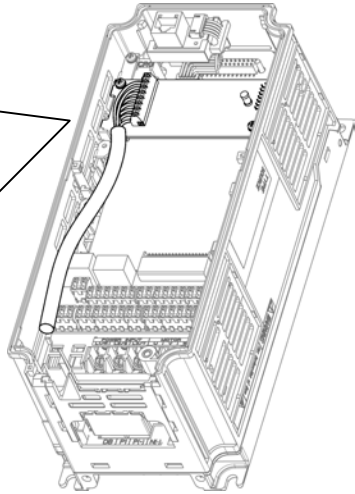
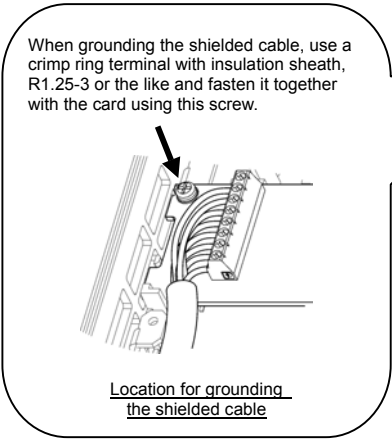

\* Pass the wires from the interface card between the control circuit terminal block and the front cover.

In the case of 0.4 kW

- For inverters with a capacity of 30 kW or above

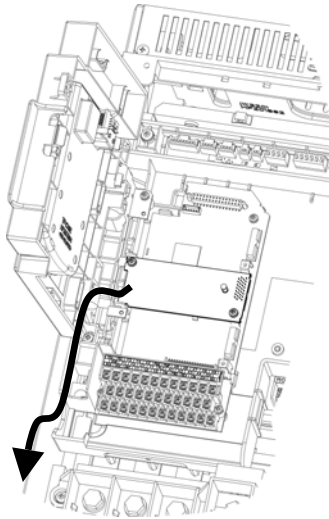

In the case of 75 kW

Figure 1.7 Examples of Wiring

1.6 Terminal Allocation on the Interface Card

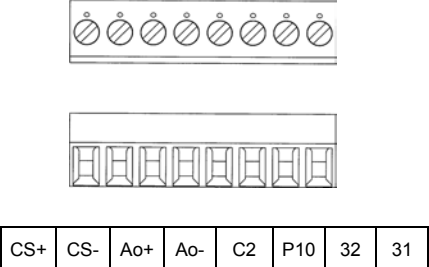

Figure 1.8 Terminal Allocation and Symbol Diagram

# Chapter 2 WIRING

## 2.1 Connection Diagram

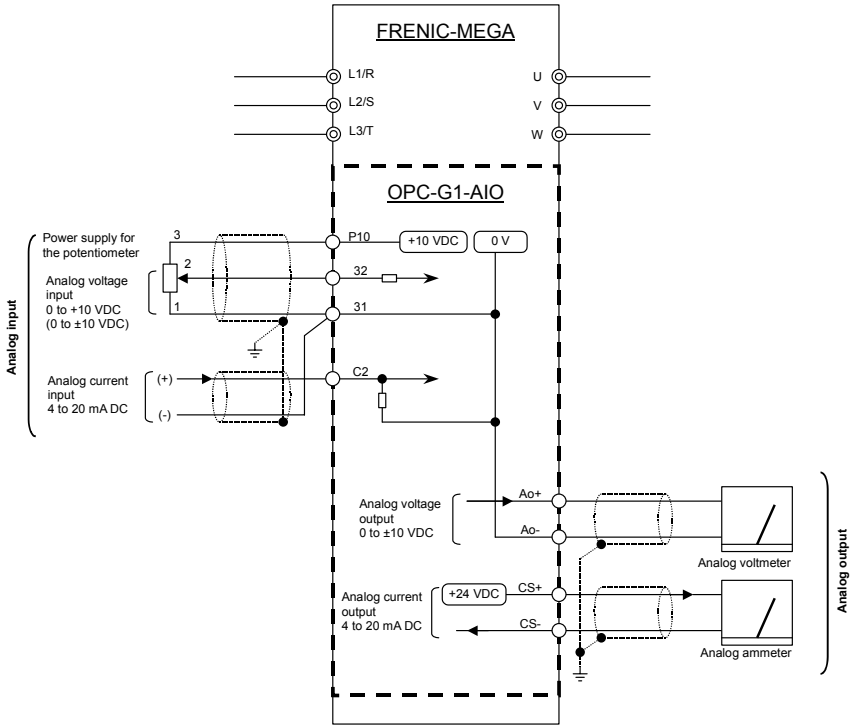

Figure 2.1 Connection Diagram

## 2.2 Terminal Functions

Table 2.1 Terminals and Their Specifications

Classifications	Symbol	Name	Functions
Analog input	P10	Power supply for the potentiometer	Power supply for frequency command potentiometer (Variable resistor: 1 to 5 k $\Omega$ ) The potentiometer of 1/2 W rating or more should be connected. (10 VDC, 10 mA DC max.)
	32	Analog voltage input	(1) Used as analog voltage input from external equipment. One of the following signals can be assigned to this terminal by specifying o60 data. <ul style="list-style-type: none"> <li>- Auxiliary frequency command</li> <li>- PID command</li> <li>- PID feedback amount</li> <li>- Ratio setting</li> <li>- Torque limiter level</li> <li>- Analog input monitor</li> </ul> (2) Hardware specifications <ul style="list-style-type: none"> <li>• Input voltage: 0 to <math>\pm 10</math> VDC/0 to <math>\pm 100\%</math> (0 to <math>\pm 5</math> VDC/0 to <math>\pm 100\%</math>)</li> <li>• Input impedance: 22 k<math>\Omega</math></li> <li>• The maximum input is <math>\pm 15</math> VDC, however, the voltage higher than <math>\pm 10</math> VDC is handled as <math>\pm 10</math> VDC.</li> <li>• Resolution: 1/3000</li> <li>• Adjustable range of the gain: 0.00 to 200%</li> </ul>
	C2	Analog current input	(1) Used as analog current input from external equipment. One of the following signals can be assigned to this terminal by specifying o66 data. <ul style="list-style-type: none"> <li>- Auxiliary frequency command</li> <li>- PID command</li> <li>- PID feedback amount</li> <li>- Ratio setting</li> <li>- Torque limiter level</li> <li>- Analog input monitor</li> </ul> (2) Hardware specifications <ul style="list-style-type: none"> <li>• Input current: 4 to 20 mA DC/0 to 100%</li> <li>• Input impedance: 250 <math>\Omega</math></li> <li>• The maximum input is +30 mA DC, however, the current larger than +20 mA DC is handled as +20 mA DC.</li> <li>• Resolution: 1/3000</li> <li>• Adjustable range of the gain: 0.00 to 200%</li> </ul>
	31	Analog common	Reference terminal for [P10], [32] and [C2]. Isolated from terminals [CS+] and [CS-]. Same potential as terminals [Ao-] and [11] on the inverter.
Analog output	Ao+	Analog voltage output (+)	(1) Outputs the monitor signal of analog DC voltage (0 to $\pm 10$ VDC). One of the following signals can be issued from this terminal by specifying o71 data. <ul style="list-style-type: none"> <li>- Output frequency</li> <li>- Output current</li> <li>- Output voltage</li> <li>- Output torque</li> <li>- Load factor</li> <li>- Input power</li> <li>- PID feedback amount</li> <li>- PG feedback value</li> <li>- DC link bus voltage</li> <li>- Universal AO</li> <li>- Motor output</li> <li>- Calibration</li> <li>- PID command (SV)</li> <li>- PID output (MV)</li> </ul> (2) Hardware specifications <ul style="list-style-type: none"> <li>• Output voltage: 0 to <math>\pm 10</math> VDC</li> <li>• Input impedance of the external device: Min. 5 k<math>\Omega</math> (at 0 to 10 VDC output) (While the terminal is outputting 0 to <math>\pm 10</math> VDC, it is capable of driving up to two analog voltmeters with 10 k<math>\Omega</math> impedance.)</li> <li>• Resolution: 1/3000</li> <li>• Adjustable range of the gain: 0 to 300%</li> </ul>
	Ao-	Analog voltage output (-)	Reference terminal for [Ao+]. Isolated from terminals [CS+] and [CS-]. Same potential as terminal [31] and [11] on the inverter.

Classifications	Symbol	Name	Functions
Analog output	CS+	Analog current output (+)	<p>(1) Outputs the monitor signal of analog DC current (4 to 20 mA DC). One of the following signals can be issued from this terminal by specifying o74 data.</p> <ul style="list-style-type: none"> <li>- Output frequency</li> <li>- Output torque</li> <li>- PID feedback amount</li> <li>- DC link bus voltage</li> <li>- Motor output</li> <li>- PID command (SV)</li> <li>- Output current</li> <li>- Load factor</li> <li>- PG feedback value</li> <li>- Universal AO</li> <li>- Calibration</li> <li>- PID output (MV)</li> <li>- Output voltage</li> <li>- Input power</li> </ul> <p>(2) Hardware specifications</p> <ul style="list-style-type: none"> <li>• Output current: 4 to 20 mA DC</li> <li>• Input impedance of the external device: Max. 500Ω (at 4 to 20 mA DC output)</li> <li>• Resolution: 1/3000</li> <li>• Adjustable range of the gain: 0 to 300%</li> </ul> <div data-bbox="456 539 848 877" style="border: 1px dashed black; padding: 10px; margin: 10px auto; width: fit-content;"> <p style="text-align: center;">&lt;Control circuit&gt;</p> <p>24 VDC → CS+</p> <p>CS- → Current source (CM (ICM on the inverter))</p> <p>Current → Ammeter</p> </div>
	CS-	Analog current output (-)	

## 2.3 Configuring Inverter's Function Codes

Table 2.2 lists the function codes related to the analog input/output interface card.

Function codes o66 through o75 become available when the interface card is connected to the inverter.

Table 2.2 Function Codes and Parameters

Function code	Name	Data setting range	Change when running *1	Data copy *2	Default setting	Drive control *3		
						V/f	w/o PG	w/ PG
o60	Terminal [32] Function (Mode selection)	0: No assignment 1: Auxiliary frequency command 1 2: Auxiliary frequency command 2 3: PID command 5: PID feedback amount 6: Ratio setting 7: Analog torque limit value A 8: Analog torque limit value B 20: Analog input monitor	N	Y	0	Y	Y	Y
o61	(Offset adjustment)	-5.0 to +5.0%	Y*	Y	0.0	Y	Y	Y
o62	(Gain adjustment)	0.00 to 200.00%	Y*	Y	100.00	Y	Y	Y
o63	(Filter setting)	0.00 to 5.00 s	Y	Y	0.05	Y	Y	Y
o64	(Gain base point)	0.00 to 100.00%	Y*	Y	100.00	Y	Y	Y
o65	(Polarity)	0: Bipolar 1: Unipolar	N	Y	1	Y	Y	Y
o66	Terminal [C2] Function (Mode selection)	0: No assignment 1: Auxiliary frequency command 1 2: Auxiliary frequency command 2 3: PID command 5: PID feedback amount 6: Ratio setting 7: Analog torque limit value A 8: Analog torque limit value B 20: Analog input monitor	N	Y	0	Y	Y	Y
o67	(Offset adjustment)	-5.0 to +5.0%	Y*	Y	0.0	Y	Y	Y
o68	(Gain adjustment)	0.00 to 200.00%	Y*	Y	100.00	Y	Y	Y
o69	(Filter setting)	0.00 to 5.00 s	Y	Y	0.05	Y	Y	Y
o70	(Gain base point)	0.00 to 100.00%	Y*	Y	100.00	Y	Y	Y

\*1 Y\*: Possible, Y: Possible, N: Impossible

(For details about Y\* and Y, refer to the FRENIC-MEGA Instruction Manual, Chapter 5, Section 5.1 "Function Code Tables.")

\*2 Y: Possible, N: Impossible

\*3 Y: Applicable, N: Not applicable



Function code	Name	Data setting range	Change when running *1	Data copy *2	Default setting	Drive control *3		
						V/f	w/o PG	w/ PG
o71	Terminal [Ao] Function (Mode selection)	0: Output frequency 1 (before slip compensation) 1: Output frequency 2 (after slip compensation) 2: Output current 3: Output voltage 4: Output torque 5: Load factor 6: Input power 7: PID feedback amount 8: PG feedback value (speed) 9: DC link bus voltage 10: Universal AO 13: Motor output 14: Calibration 15: PID command (SV) 16: PID output (MV)	Y	Y	0	Y	Y	Y
o72	(Gain to output voltage)	0 to 300%	Y*	Y	100	Y	Y	Y
o73	(Polarity)	0: Bipolar 1: Unipolar	Y	Y	1	Y	Y	Y
o74	Terminal [CS] Function (Mode selection)	0: Output frequency 1 (before slip compensation) 1: Output frequency 2 (after slip compensation) 2: Output current 3: Output voltage 4: Output torque 5: Load factor 6: Input power 7: PID feedback amount 8: PG feedback value (speed) 9: DC link bus voltage 10: Universal AO 13: Motor output 14: Calibration 15: PID command (SV) 16: PID output (MV)	Y	Y	0	Y	Y	Y
o75	(Gain to output current)	0 to 300%	Y*	Y	100	Y	Y	Y

\*1 Y\*: Possible, Y: Possible, N: Impossible  
(For details about Y\* and Y, refer to the FRENIC-MEGA Instruction Manual, Chapter 5, Section 5.1 "Function Code Tables.")

\*2 Y: Possible, N: Impossible

\*3 Y: Applicable, N: Not applicable

## 2.4 Function Codes Details

This section details the function codes.

### ■ AI function (o60 and o66)

Configure function codes o60 and o66 to assign functions to terminals [32] and [C2].

o60	o66	Function	Description
0	0	No assignment	The analog input function is disabled by default.
1	1	Auxiliary frequency command 1	0 to $\pm 10$ V/0 to $\pm 100\%$ 4 to 20 mA/0 to $+100\%$
2	2	Auxiliary frequency command 2	<ul style="list-style-type: none"> <li>• <math>\pm 100\%</math> = Maximum frequency</li> <li>• Positive during forward rotation</li> <li>• Negative during reverse rotation</li> </ul>
3	3	PID command	0 to $\pm 10$ V/0 to $\pm 100\%$ 4 to 20 mA/0 to $+100\%$ <ul style="list-style-type: none"> <li>• Under PID process control: Unipolar</li> <li>• Under dancer reference position control: Bipolar</li> <li>• <math>\pm 100\%</math> = 100% of the PID command</li> </ul>
5	5	PID feedback amount	0 to $\pm 10$ V/0 to $\pm 100\%$ 4 to 20 mA/0 to $+100\%$ <ul style="list-style-type: none"> <li>• <math>\pm 100\%</math> = 100% of the PID feedback amount</li> </ul>
6	6	Ratio setting	0 to $+10$ V/0 to $+100\%$ 4 to 20 mA/0 to $+100\%$ <ul style="list-style-type: none"> <li>• <math>+100\%</math> = Ratio 1</li> </ul>
7	7	Analog torque limit value A	0 to $\pm 10$ V/0 to $\pm 100\%$ 4 to 20 mA/0 to $+100\%$
8	8	Analog torque limit value B	<ul style="list-style-type: none"> <li>• <math>\pm 100\%</math> = <math>\pm 200\%</math> of the rated motor torque</li> </ul>
20	20	Analog input monitor	0 to $+10$ V/ Display coefficient B (E41) to display coefficient A (E42) 4 to 20 mA/ Display coefficient B (E41) to display coefficient A (E42)

■ Gain (o62, o64, o68 and o70)

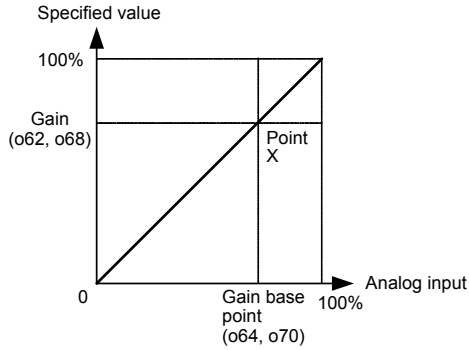

■ Filter (o63 and o69)

o63 and o69 configure a filter time constant for an analog voltage and current input, respectively. The larger the time constant, the slower the response. Specify the proper filter time constant taking into account the response speed of the machine (load).

- Data setting range: 0.00 to 5.00 (s)

■ Polarity (o65)

o65 configures the input range for analog input voltage.

o65	Specifications for terminal input
0	-10 to +10 V
1	0 to +10 V (A negative component of the input will be regarded as 0 VDC.)

■ AO function (o71 and o74)

Configure function codes o71 and o74 to assign functions to terminals [Ao] and [CS].

o71	o74	Function	Description
0	0	Output frequency 1 (before slip compensation)	0 to $\pm 10$ V/0 to $\pm 100\%$ 4 to 20 mA/0 to $+100\%$
1	1	Output frequency 2 (after slip compensation)	• 100% = Maximum frequency
2	2	Output current	0 to $\pm 10$ V/0 to $\pm 200\%$ 4 to 20 mA/0 to $+200\%$ • 100% = Inverter rated current
3	3	Output voltage	200 V class series: 0 to $+10$ V/0 to $+250$ V 4 to 20 mA/0 to $+250$ V 400 V class series: 0 to $+10$ V/0 to $+500$ V 4 to 20 mA/0 to $+500$ V
4	4	Output torque	0 to $\pm 10$ V/0 to $\pm 200\%$ 4 to 20 mA/0 to $+200\%$ • 100% = Motor rated torque
5	5	Load factor	0 to $+10$ V/0 to $+200\%$ 4 to 20 mA/0 to $+200\%$ • 100% = Motor rated load
6	6	Input power	0 to $+10$ V/0 to $+200\%$ 4 to 20 mA/0 to $+200\%$ • 100% = Inverter rated output
7	7	PID feedback amount	0 to $+10$ V/0 to $+100\%$ 4 to 20 mA/0 to $+100\%$ • 100% = 100% of the PID feedback amount
8	8	PG feedback value (speed)	0 to $\pm 10$ V/0 to $\pm 100\%$ 4 to 20 mA/0 to $+100\%$ • 100% = Maximum frequency
9	9	DC link bus voltage	200 V class series: 0 to $+10$ V/0 to $+500$ V 4 to 20 mA/0 to $+500$ V 400 V class series: 0 to $+10$ V/0 to $+1000$ V 4 to 20 mA/0 to $+1000$ V
10	10	Universal AO	0 to $\pm 10$ V/0 to $\pm 100\%$ 4 to 20 mA/0 to $+100$ • 100% = 20000d
11	11	Motor output	0 to $\pm 10$ V/0 to $\pm 200\%$ 4 to 20 mA/0 to $+200\%$ • 100% = Motor rated output
13	13	Calibration	Outputs 10 V or 20 mA.
14	14	PID command (SV)	0 to $\pm 10$ V/0 to $\pm 100\%$ • 100% = Feedback amount
15	15	PID output (MV)	0 to $\pm 10$ V/0 to $\pm 100\%$ • 100% = Maximum frequency

■ Gain (o72 and o75)

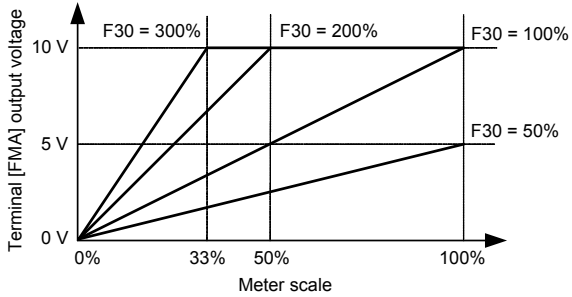

■ Polarity (o73)

o73 configures the output range for analog output voltage.

o73	Specifications for terminal input
0	-10 to +10 V
1	0 to +10 V (A negative component reverses the output. Example: -5V → +5V)

## Chapter 3 I/O CHECKING

Using Menu #4 "I/O Checking" in FRENIC-MEGA program mode displays the I/O status of external signals on the LED monitor of the keypad.

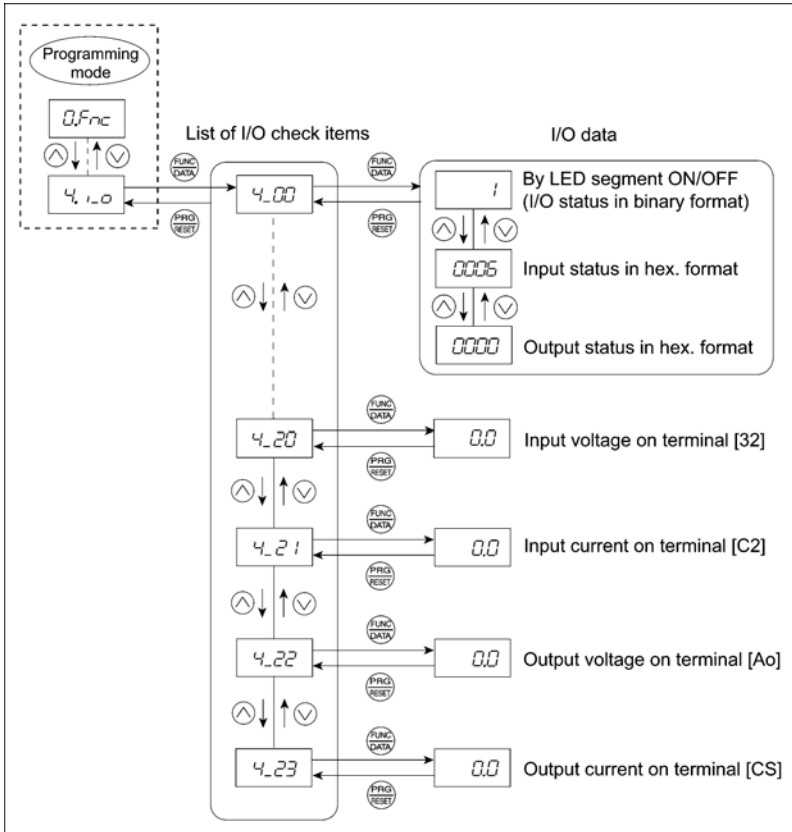

Figure 3.1 Menu Transition in Menu #4 "I/O Checking"

### Basic key operation

To check the status of the I/O signals, set function code E52 to "2" (Full-menu mode) beforehand.

- (1) Turn the inverter ON. It automatically enters Running mode. In that mode, press the key to switch to Programming mode. The function selection menu appears.
- (2) Use the and keys to display "I/O Checking" (4.1.0).
- (3) Press the key to proceed to a list of I/O check items (e.g. 4.00).
- (4) Use the and keys to display the desired I/O check item, then press the key. The corresponding I/O check data appears.
- (5) Press the key to return to the list of I/O check items. Press the key again to return to the menu.

For details of Menu #4 "I/O Checking," refer to the FRENIC-MEGA Instruction Manual, Chapter 3, Section 3.4 "Programming Mode."

Table 3.1 I/O Check Items

LED monitor shows:	Item	Description
4_20	Input voltage on terminal [32]	Shows the input voltage on terminal [32] in volts (V).
4_21	Input current on terminal [C2]	Shows the input current on terminal [C2] in milliamperes (mA).
4_22	Output voltage on terminal [Ao]	Shows the output voltage on terminal [Ao] in volts (V).
4_23	Output current on terminal [CS]	Shows the output current on terminal [CS] in milliamperes (mA).

## Chapter 4 PROTECTIVE FUNCTION

### Option communications error (E-4)

**Problem** A communications error occurred between the analog input/output interface card and the inverter.

Possible Causes	What to Check and Suggested Measures
(1) There is a problem with the connection between the interface card and the inverter.	Check whether the connector on the interface card is firmly engaged with that of the inverter. → Reload the interface card into the inverter.
(2) Strong electrical noise.	Check whether appropriate noise control measures have been implemented (e.g. correct grounding and routing of signal wires, communications cables, and main circuit wires). → Implement noise control measures.
(3) Two or more interface cards of the same type are mounted.	Check whether two or more interface cards of the same type are mounted. → Limit the number of interface cards of the same type on an inverter to only one.



When no o code is displayed even if an interface card is mounted, check whether the connector on the interface card is firmly engaged with that of the inverter. In this case, E-4 does not appear.

### Option error (E-5)

**Problem** An error occurred on the analog input/output interface card.

Possible Causes	What to Check and Suggested Measures
(1) An error occurred on the interface card mounted on the inverter.	Check whether this error is due to the interface card itself. → The CPU or its printed circuit board (PCB) is defective. Contact your Fuji Electric representative.



MEMO

**アナログ入出カインタフェースカード / Digital Input/Output Interface Card  
"OPC-G1-AIO"**

---

**取扱説明書 / Instruction Manual**

First Edition, April 2008

Fuji Electric FA Components & Systems Co., Ltd.

---

- この取扱説明書の一部または全部を無断で複製・転載することはお断りします。
- この説明書の内容は将来予告なしに変更することがあります。
- 本書の内容については、万全を期して作成いたしましたですが、万一ご不審の点や誤り、記載もれなど、お気づきの点がありましたら、ご連絡ください。
- 運用した結果の影響については、上項にかかわらず責任を負いかねますのでご了承ください。

The purpose of this manual is to provide accurate information in the handling, setting up and operating of the analog input/output interface card for the FRENIC-MEGA series of inverters. Please feel free to send your comments regarding any errors or omissions you may have found, or any suggestions you may have for generally improving the manual.

In no event will Fuji Electric FA Components & Systems Co., Ltd. be liable for any direct or indirect damages resulting from the application of the information in this manual.

---

## 富士電機機器制御株式会社

システム機器事業部

〒103-0011 東京都中央区日本橋大伝馬町 5 番 7 号  
(三井住友銀行人形町ビル)

URL <http://www.fujielectric.co.jp/fcs/>

## Fuji Electric FA Components & Systems Co., Ltd.

Mitsui Sumitomo Bank Ningyo-cho Bldg., 5-7,  
Nihonbashi, Odemma-cho, Chuo-ku, Tokyo,  
103-0011, Japan

Phone: +81 3 5847 8011 Fax: +81 3 5847 8172

URL <http://www.fujielectric.co.jp/fcs/>